

2002 Cessna SN 560-0598

Citation Encore



CLICK TO VIEW
VIRTUAL TOUR



CLICK TO VIEW
VIDEO



AVPRO INC.
www.avprojets.com

EXECUTIVE SALES DIRECTOR

Wesley Ray
wray@avprojets.com
+1.410.573.1515

2002 Citation Encore SN 560-0598 N757TR

Aircraft Listing Details:

Total Hours: 6938

Total Landings: 5551

Engines: Pratt & Whitney 535A

	#1	#2
Total Hours:	5967	6182
Hours Since Overhaul:	1216	1216
Serial Numbers:	PCE-DC0162	PCE-DC0163

Aircraft Highlights:

- Dual Garmin GTN-750 NAV/COM/GPS
- Garmin GTX-3000 Transponders w/ADS-B Out
- Phase 1-4 Inspections c/w January 2023
- Phase 5 Inspection c/w January 2024

Avionics:

- Honeywell Primus 1000 Integrated Avionics System
- Dual Garmin GTN-750 NAV/COM/GPS Units
- Dual Garmin GTX-3000 Transponders w/ADS-B Out
- Honeywell Mark VII EGPWS w/Windshear
- Honeywell CAS-67A TCAS-II
- Honeywell RT-300 Radio Altimeter
- Honeywell Primus WU-660 Radar
- Fairchild FA2100 Cockpit Voice Recorder
- Artex 110-4 Three Frequency ELT

SPECIFICATIONS ARE PROVIDED FOR INFORMATIONAL PURPOSES ONLY AND DO NOT CONSTITUTE REPRESENTATIONS OR WARRANTIES. THESE SPECIFICATIONS ARE SUBJECT TO BUYER'S INDEPENDENT VERIFICATION UPON INSPECTION.
THE AIRCRAFT IS SUBJECT TO PRIOR SALE, LEASE AND/OR REMOVAL FROM THE MARKET WITHOUT PRIOR NOTICE. JANUARY 8, 2024 4:40 PM

2002 Citation Encore SN 560-0598 N757TR

Navigation Compliance:

- ADS-B Out & WAAS/LPV
- Honeywell CAS-67A TCAS-II
- RVSM / 8.33 Spacing

Features / Options:

- Freon Air Conditioning
- Extended Baggage w/ Ski Tube

Interior:

Seven (7) passenger configuration featuring a forward RS Refreshment Center and a single (1) aft facing chair. Moving aft, there is a four (4) place club followed by two (2) forward facing chairs. The aft flushing lavatory is belted for an eighth passenger.

All chairs are covered in beige colored leather, complimented by patterned lower sidewalls, light colored and textured upper sidewalls. The high gloss medium-colored woodwork is complimented by the rose-colored metal plating.

Exterior:

Overall White with Ruby, Black & Silver Metallic Accent Striping.

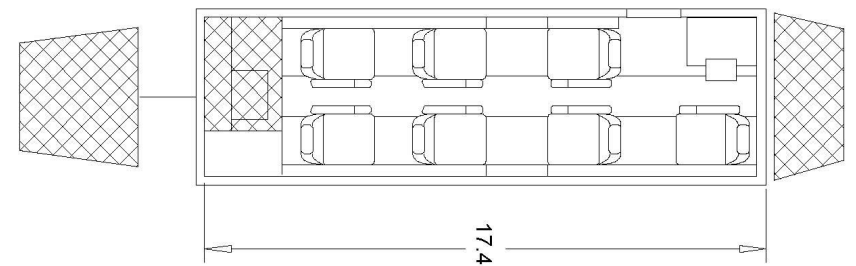
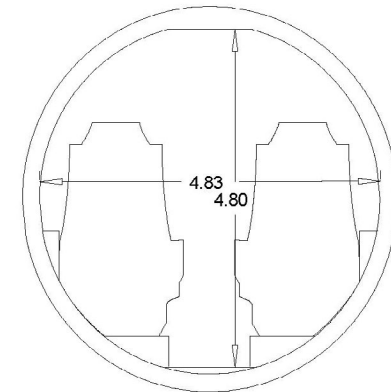
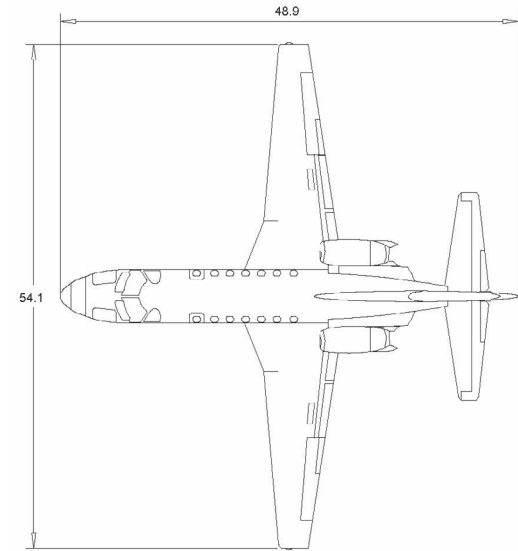

SPECIFICATIONS ARE PROVIDED FOR INFORMATIONAL PURPOSES ONLY AND DO NOT CONSTITUTE REPRESENTATIONS OR WARRANTIES. THESE SPECIFICATIONS ARE SUBJECT TO BUYER'S INDEPENDENT VERIFICATION UPON INSPECTION. THE AIRCRAFT IS SUBJECT TO PRIOR SALE, LEASE AND/OR REMOVAL FROM THE MARKET WITHOUT PRIOR NOTICE. JANUARY 8, 2024 4:40 PM

2002 Citation Encore SN 560-0598 N757TR



SPECIFICATIONS ARE PROVIDED FOR INFORMATIONAL PURPOSES ONLY AND DO NOT CONSTITUTE REPRESENTATIONS OR WARRANTIES. THESE SPECIFICATIONS ARE SUBJECT TO BUYER'S INDEPENDENT VERIFICATION UPON INSPECTION.
THE AIRCRAFT IS SUBJECT TO PRIOR SALE, LEASE AND/OR REMOVAL FROM THE MARKET WITHOUT PRIOR NOTICE. JANUARY 8, 2024 4:40 PM

AVPROJETS.COM
info@avprojets.com

900 Bestgate Road Suite 412 Annapolis, MD 21401
+1.410.573.1515

Wesley Ray
wray@avprojets.com

2002 Citation Encore SN 560-0598 N757TR



SPECIFICATIONS ARE PROVIDED FOR INFORMATIONAL PURPOSES ONLY AND DO NOT CONSTITUTE REPRESENTATIONS OR WARRANTIES. THESE SPECIFICATIONS ARE SUBJECT TO BUYER'S INDEPENDENT VERIFICATION UPON INSPECTION.
THE AIRCRAFT IS SUBJECT TO PRIOR SALE, LEASE AND/OR REMOVAL FROM THE MARKET WITHOUT PRIOR NOTICE. JANUARY 8, 2024 4:40 PM

AVPROJETS.COM
info@avprojets.com

900 Bestgate Road Suite 412 Annapolis, MD 21401
+1.410.573.1515

Wesley Ray
wray@avprojets.com

2002 Citation Encore SN 560-0598 N757TR



SPECIFICATIONS ARE PROVIDED FOR INFORMATIONAL PURPOSES ONLY AND DO NOT CONSTITUTE REPRESENTATIONS OR WARRANTIES. THESE SPECIFICATIONS ARE SUBJECT TO BUYER'S INDEPENDENT VERIFICATION UPON INSPECTION.
THE AIRCRAFT IS SUBJECT TO PRIOR SALE, LEASE AND/OR REMOVAL FROM THE MARKET WITHOUT PRIOR NOTICE. JANUARY 8, 2024 4:40 PM

AVPROJETS.COM
info@avprojets.com

900 Bestgate Road Suite 412 Annapolis, MD 21401
+1.410.573.1515

Wesley Ray
wray@avprojets.com

2002 Citation Encore SN 560-0598 N757TR



SPECIFICATIONS ARE PROVIDED FOR INFORMATIONAL PURPOSES ONLY AND DO NOT CONSTITUTE REPRESENTATIONS OR WARRANTIES. THESE SPECIFICATIONS ARE SUBJECT TO BUYER'S INDEPENDENT VERIFICATION UPON INSPECTION.
THE AIRCRAFT IS SUBJECT TO PRIOR SALE, LEASE AND/OR REMOVAL FROM THE MARKET WITHOUT PRIOR NOTICE. JANUARY 8, 2024 4:40 PM

AVPROJETS.COM
info@avprojets.com

900 Bestgate Road Suite 412 Annapolis, MD 21401
+1.410.573.1515

Wesley Ray
wray@avprojets.com

2002 Citation Encore SN 560-0598 N757TR



SPECIFICATIONS ARE PROVIDED FOR INFORMATIONAL PURPOSES ONLY AND DO NOT CONSTITUTE REPRESENTATIONS OR WARRANTIES. THESE SPECIFICATIONS ARE SUBJECT TO BUYER'S INDEPENDENT VERIFICATION UPON INSPECTION.
THE AIRCRAFT IS SUBJECT TO PRIOR SALE, LEASE AND/OR REMOVAL FROM THE MARKET WITHOUT PRIOR NOTICE. JANUARY 8, 2024 4:40 PM

AVPROJETS.COM
info@avprojets.com

900 Bestgate Road Suite 412 Annapolis, MD 21401
+1.410.573.1515

Wesley Ray
wray@avprojets.com

2002 Citation Encore SN 560-0598 N757TR



SPECIFICATIONS ARE PROVIDED FOR INFORMATIONAL PURPOSES ONLY AND DO NOT CONSTITUTE REPRESENTATIONS OR WARRANTIES. THESE SPECIFICATIONS ARE SUBJECT TO BUYER'S INDEPENDENT VERIFICATION UPON INSPECTION.
THE AIRCRAFT IS SUBJECT TO PRIOR SALE, LEASE AND/OR REMOVAL FROM THE MARKET WITHOUT PRIOR NOTICE. JANUARY 8, 2024 4:40 PM

AVPROJETS.COM
info@avprojets.com

900 Bestgate Road Suite 412 Annapolis, MD 21401
+1.410.573.1515

Wesley Ray
wray@avprojets.com

2002 Citation Encore SN 560-0598 N757TR



SPECIFICATIONS ARE PROVIDED FOR INFORMATIONAL PURPOSES ONLY AND DO NOT CONSTITUTE REPRESENTATIONS OR WARRANTIES. THESE SPECIFICATIONS ARE SUBJECT TO BUYER'S INDEPENDENT VERIFICATION UPON INSPECTION.
THE AIRCRAFT IS SUBJECT TO PRIOR SALE, LEASE AND/OR REMOVAL FROM THE MARKET WITHOUT PRIOR NOTICE. JANUARY 8, 2024 4:40 PM

AVPROJETS.COM
info@avprojets.com

900 Bestgate Road Suite 412 Annapolis, MD 21401
+1.410.573.1515

Wesley Ray
wray@avprojets.com

2002 Citation Encore SN 560-0598 N757TR



SPECIFICATIONS ARE PROVIDED FOR INFORMATIONAL PURPOSES ONLY AND DO NOT CONSTITUTE REPRESENTATIONS OR WARRANTIES. THESE SPECIFICATIONS ARE SUBJECT TO BUYER'S INDEPENDENT VERIFICATION UPON INSPECTION. THE AIRCRAFT IS SUBJECT TO PRIOR SALE, LEASE AND/OR REMOVAL FROM THE MARKET WITHOUT PRIOR NOTICE. JANUARY 8, 2024 4:40 PM

2002 Citation Encore SN 560-0598 N757TR



SPECIFICATIONS ARE PROVIDED FOR INFORMATIONAL PURPOSES ONLY AND DO NOT CONSTITUTE REPRESENTATIONS OR WARRANTIES. THESE SPECIFICATIONS ARE SUBJECT TO BUYER'S INDEPENDENT VERIFICATION UPON INSPECTION.
THE AIRCRAFT IS SUBJECT TO PRIOR SALE, LEASE AND/OR REMOVAL FROM THE MARKET WITHOUT PRIOR NOTICE. JANUARY 8, 2024 4:40 PM

AVPROJETS.COM
info@avprojets.com

900 Bestgate Road Suite 412 Annapolis, MD 21401
+1.410.573.1515

Wesley Ray
wray@avprojets.com

2002 Citation Encore SN 560-0598 N757TR



SPECIFICATIONS ARE PROVIDED FOR INFORMATIONAL PURPOSES ONLY AND DO NOT CONSTITUTE REPRESENTATIONS OR WARRANTIES. THESE SPECIFICATIONS ARE SUBJECT TO BUYER'S INDEPENDENT VERIFICATION UPON INSPECTION.
THE AIRCRAFT IS SUBJECT TO PRIOR SALE, LEASE AND/OR REMOVAL FROM THE MARKET WITHOUT PRIOR NOTICE. JANUARY 8, 2024 4:40 PM

AVPROJETS.COM
info@avprojets.com

900 Bestgate Road Suite 412 Annapolis, MD 21401
+1.410.573.1515

Wesley Ray
wray@avprojets.com

2002 Citation Encore SN 560-0598 N757TR



SPECIFICATIONS ARE PROVIDED FOR INFORMATIONAL PURPOSES ONLY AND DO NOT CONSTITUTE REPRESENTATIONS OR WARRANTIES. THESE SPECIFICATIONS ARE SUBJECT TO BUYER'S INDEPENDENT VERIFICATION UPON INSPECTION.
THE AIRCRAFT IS SUBJECT TO PRIOR SALE, LEASE AND/OR REMOVAL FROM THE MARKET WITHOUT PRIOR NOTICE. JANUARY 8, 2024 4:40 PM

AVPROJETS.COM
info@avprojets.com

900 Bestgate Road Suite 412 Annapolis, MD 21401
+1.410.573.1515

Wesley Ray
wray@avprojets.com

2002 Citation Encore SN 560-0598 N757TR



SPECIFICATIONS ARE PROVIDED FOR INFORMATIONAL PURPOSES ONLY AND DO NOT CONSTITUTE REPRESENTATIONS OR WARRANTIES. THESE SPECIFICATIONS ARE SUBJECT TO BUYER'S INDEPENDENT VERIFICATION UPON INSPECTION.
THE AIRCRAFT IS SUBJECT TO PRIOR SALE, LEASE AND/OR REMOVAL FROM THE MARKET WITHOUT PRIOR NOTICE. JANUARY 8, 2024 4:40 PM

AVPROJETS.COM
info@avprojets.com

900 Bestgate Road Suite 412 Annapolis, MD 21401
+1.410.573.1515

Wesley Ray
wray@avprojets.com

2002 Citation Encore SN 560-0598 N757TR



SPECIFICATIONS ARE PROVIDED FOR INFORMATIONAL PURPOSES ONLY AND DO NOT CONSTITUTE REPRESENTATIONS OR WARRANTIES. THESE SPECIFICATIONS ARE SUBJECT TO BUYER'S INDEPENDENT VERIFICATION UPON INSPECTION. THE AIRCRAFT IS SUBJECT TO PRIOR SALE, LEASE AND/OR REMOVAL FROM THE MARKET WITHOUT PRIOR NOTICE. JANUARY 8, 2024 4:40 PM

AVPROJETS.COM
info@avprojets.com

900 Bestgate Road Suite 412 Annapolis, MD 21401
+1.410.573.1515

Wesley Ray
wray@avprojets.com



SPECIFICATIONS ARE PROVIDED FOR INFORMATIONAL PURPOSES ONLY AND DO NOT CONSTITUTE REPRESENTATIONS OR WARRANTIES. THESE SPECIFICATIONS ARE SUBJECT TO BUYER'S INDEPENDENT VERIFICATION UPON INSPECTION.
THE AIRCRAFT IS SUBJECT TO PRIOR SALE, LEASE AND/OR REMOVAL FROM THE MARKET WITHOUT PRIOR NOTICE. JANUARY 8, 2024 4:40 PM



SPECIFICATIONS ARE PROVIDED FOR INFORMATIONAL PURPOSES ONLY AND DO NOT CONSTITUTE REPRESENTATIONS OR WARRANTIES. THESE SPECIFICATIONS ARE SUBJECT TO BUYER'S INDEPENDENT VERIFICATION UPON INSPECTION.
THE AIRCRAFT IS SUBJECT TO PRIOR SALE, LEASE AND/OR REMOVAL FROM THE MARKET WITHOUT PRIOR NOTICE. JANUARY 8, 2024 4:40 PM



AVPRO INC.

CELEBRATING OVER **30** YEARS OF EXCELLENCE

We perform for our clients, averaging two transactions a week.

We match aircraft to your specifications in a professional and timely manner, allowing you to concentrate on your business, leaving the important details of marketing, market research, negotiating and contracting to us.

Avpro offers aircraft financing advisory services. We have the expertise to navigate the appropriate structure, costs and terms to help you meet your objectives. We are ready to provide advice, analysis and sourcing of the lender best suited to meet your requirements.

SERVING CUSTOMERS
AROUND THE GLOBE

Talk to Us info@avprojets.com +1.410.573.1515

Connect with Us LINKEDIN FACEBOOK TWITTER INSTAGRAM



AVPROJETS.COM
info@avprojets.com

900 Bestgate Road Suite 412 Annapolis, MD 21401
+1.410.573.1515

Wesley Ray
wray@avprojets.com