

1988 Gulfstream ^{SN} 1074

GIV



CLICK TO VIEW
VIRTUAL TOUR



AVPRO INC.
www.avprojets.com

EXECUTIVE SALES DIRECTOR

Anderson Bell
abell@avprojets.com
+1.410.573.1515

1988 Gulfstream IV SN 1074 N995GG

Preliminary Specification - Information Subject to Verification

Aircraft Listing Details:

Total Hours: 12,299
Total Landings: 4,839

Engines: Rolls Royce TAY 611-8 (GIV)

| | #1 | #2 |
|-----------------|--------|--------|
| Total Hours: | 11,775 | 11,580 |
| Engine Cycles: | 4,616 | 4,504 |
| Midlife Due: | 6/2024 | 5/2026 |
| Serial Numbers: | 16260 | 16257 |

APU: Honeywell GTCP36-100 (GIV) **New 2021**

Total Hours: 2,483
Serial Number: P-766

Aircraft Highlights:

- Excellent Ownership Pedigree - Same US Owner Since 2007
- DPI Labs Smartlink Cabin Management System
- New Paint by Straube Aviation, June 2021
- New APU 2021
- New RH Windshield
- ASC-190 Gross Weight Increase
- AirCell ATG-4000 Go-Go Biz Inflight Internet
- 5,000 Landing Structural Inspections c/w (not including TR's)
- Thrust Reverser Overhauls Due at 5,000 Cycles
- Enrolled on MSP Avionics (Formerly HAPP)
- Enrolled on MSP Mechanical (Formerly MPP)
- Part 135 Capable

Avionics:

- Honeywell SPZ-8000 Six Tube EFIS / Pro Line 4
- Honeywell SPZ-8000 Flight Director / AutoPilot
- Dual Honeywell NZ-2000 Flight Guidance Computer
- Dual Collins VHF-422C Comms w/8.33 Spacing
- Single VHF-422B Comm
- Triple Collins VIR-432 NAV Receivers
- Dual Collins ADF-462 ADFs
- Dual Collins DME-442 DMEs
- Dual Honeywell CD-810 CDUs
- Dual Honeywell DA-884 Data Acquisition Units
- Honeywell DL-950 Data Loader
- Dual Bendix King Transponders
- Dual Honeywell FMS NZ-2000 Version 5.2
- Honeywell GPS Sensors
- Triple Honeywell LASEREF II IRUs
- Honeywell Primus 870 Color Weather Radar
- Dual Honeywell RT-300 Radio Altimeter System
- Sperry LP-850 Lightning Receiver/Processor
- Allied Signal EGPWS (TSO-C92c)
- ACSS TCAS II w/Change 7.0
- Dual Collins HF Receivers
- Motorola SELCAL Decoder
- Fairchild CVR Cockpit Voice Recorder
- Fairchild F1000 FDR Flight Data Recorder
- L3 MicroQAR200
- Artex C406 ELT
- Honeywell AFIS

SPECIFICATIONS ARE PROVIDED FOR INFORMATIONAL PURPOSES ONLY AND DO NOT CONSTITUTE REPRESENTATIONS OR WARRANTIES. THESE SPECIFICATIONS ARE SUBJECT TO BUYER'S INDEPENDENT VERIFICATION UPON INSPECTION.
THE AIRCRAFT IS SUBJECT TO PRIOR SALE, LEASE AND/OR REMOVAL FROM THE MARKET WITHOUT PRIOR NOTICE. AUGUST 24, 2023 2:16 PM

1988 Gulfstream IV SN 1074 N995GG

Preliminary Specification - Information Subject to Verification

Connectivity:

- AirCell ATG-4000 Go-Go Biz Inflight Internet

Entertainment:

- DPI Labs Smartlink Cabin Management System
- Airshow 410 w/Global Map Display
- Three (3) Zone Audio/Visual
- Dual Blu-Ray Players
- Dual Apple Device Docking Stations
- Forward & Aft Bulkhead Mounted Monitors
- Four (4) Individual HD Monitors

Maintenance Programs:

- Enrolled on MSP Avionics (Formerly HAPP)
- Enrolled on MSP Mechanical (Formerly MPP)
- Enrolled on GCMP

Inspection Status:

- 5,000 Landing Structural Inspections c/w (not including TR's)
- Thrust Reverser Overhauls Due at 5,000 Cycles

Navigation Compliance:

- RVSM, MNPS, B-RNAV, RNP5, RNP10
- Part 135 Capable

Features/Options:

- ASC-190 Gross Weight Increase
- New RH Windshield
- Dual PZ-800 Performance Auto Throttles
- Three Zone Enhanced LED Lighting (New 2012)

Interior: *Refurbished by Plane Perfect, December 2012*

Thirteen (13) Passenger Forward Galley Configuration.

Forward Cabin:

Four (4) Place Divan Opposite a Two (2) Place Club

Mid Cabin:

Four (4) Place Club

Aft Cabin:

Three (3) Place Divan Opposite an Entertainment Cabinet

Exterior: *New Paint by Straube Aviation, June 2021*

Overall White w/Black & Silver Accent Striping.

SPECIFICATIONS ARE PROVIDED FOR INFORMATIONAL PURPOSES ONLY AND DO NOT CONSTITUTE REPRESENTATIONS OR WARRANTIES. THESE SPECIFICATIONS ARE SUBJECT TO BUYER'S INDEPENDENT VERIFICATION UPON INSPECTION.
THE AIRCRAFT IS SUBJECT TO PRIOR SALE, LEASE AND/OR REMOVAL FROM THE MARKET WITHOUT PRIOR NOTICE. AUGUST 24, 2023 2:16 PM

1988 Gulfstream IV SN 1074 N995GG

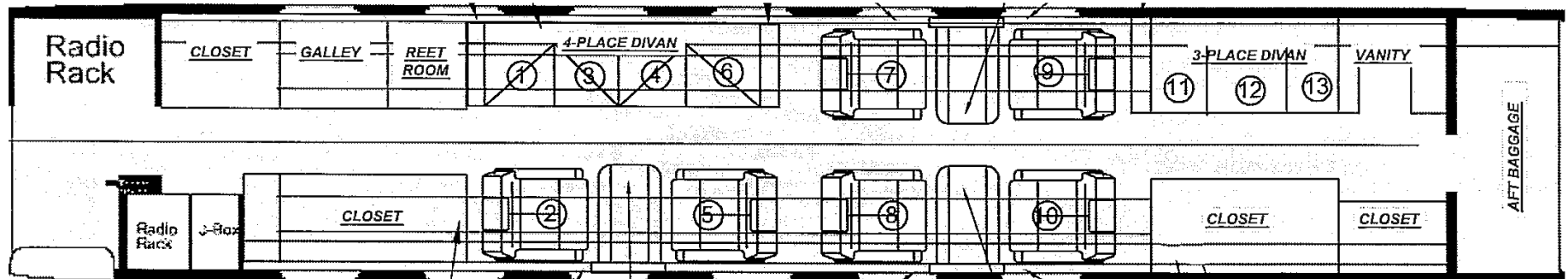
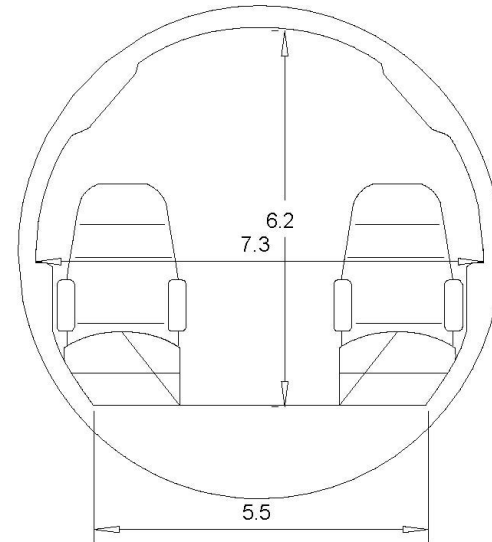
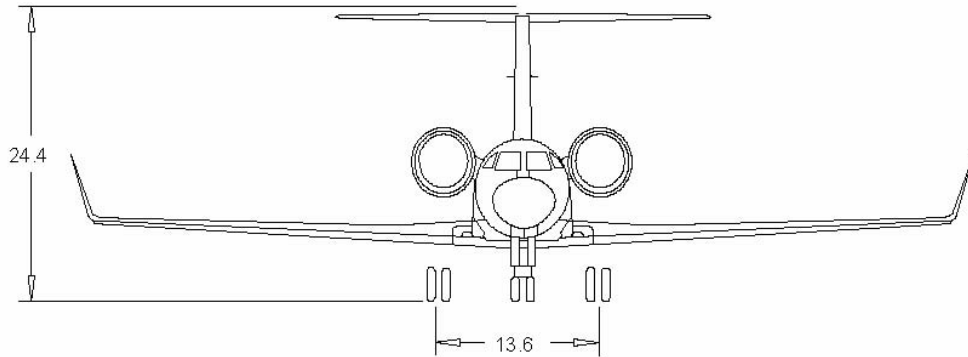

SPECIFICATIONS ARE PROVIDED FOR INFORMATIONAL PURPOSES ONLY AND DO NOT CONSTITUTE REPRESENTATIONS OR WARRANTIES. THESE SPECIFICATIONS ARE SUBJECT TO BUYER'S INDEPENDENT VERIFICATION UPON INSPECTION. THE AIRCRAFT IS SUBJECT TO PRIOR SALE, LEASE AND/OR REMOVAL FROM THE MARKET WITHOUT PRIOR NOTICE. AUGUST 24, 2023 2:16 PM

1988 Gulfstream IV SN 1074 N995GG



SPECIFICATIONS ARE PROVIDED FOR INFORMATIONAL PURPOSES ONLY AND DO NOT CONSTITUTE REPRESENTATIONS OR WARRANTIES. THESE SPECIFICATIONS ARE SUBJECT TO BUYER'S INDEPENDENT VERIFICATION UPON INSPECTION.
THE AIRCRAFT IS SUBJECT TO PRIOR SALE, LEASE AND/OR REMOVAL FROM THE MARKET WITHOUT PRIOR NOTICE. AUGUST 24, 2023 2:16 PM

AVPROJETS.COM
info@avprojets.com

900 Bestgate Road Suite 412 Annapolis, MD 21401
+1.410.573.1515

Anderson Bell
abell@avprojets.com

1988 Gulfstream IV SN 1074 N995GG



SPECIFICATIONS ARE PROVIDED FOR INFORMATIONAL PURPOSES ONLY AND DO NOT CONSTITUTE REPRESENTATIONS OR WARRANTIES. THESE SPECIFICATIONS ARE SUBJECT TO BUYER'S INDEPENDENT VERIFICATION UPON INSPECTION.
THE AIRCRAFT IS SUBJECT TO PRIOR SALE, LEASE AND/OR REMOVAL FROM THE MARKET WITHOUT PRIOR NOTICE. AUGUST 24, 2023 2:16 PM

AVPROJETS.COM
info@avprojets.com

900 Bestgate Road Suite 412 Annapolis, MD 21401
+1.410.573.1515

Anderson Bell
abell@avprojets.com

1988 Gulfstream IV SN 1074 N995GG



SPECIFICATIONS ARE PROVIDED FOR INFORMATIONAL PURPOSES ONLY AND DO NOT CONSTITUTE REPRESENTATIONS OR WARRANTIES. THESE SPECIFICATIONS ARE SUBJECT TO BUYER'S INDEPENDENT VERIFICATION UPON INSPECTION.
THE AIRCRAFT IS SUBJECT TO PRIOR SALE, LEASE AND/OR REMOVAL FROM THE MARKET WITHOUT PRIOR NOTICE. AUGUST 24, 2023 2:16 PM

AVPROJETS.COM
info@avprojets.com

900 Bestgate Road Suite 412 Annapolis, MD 21401
+1.410.573.1515

Anderson Bell
abell@avprojets.com

1988 Gulfstream IV SN 1074 N995GG



SPECIFICATIONS ARE PROVIDED FOR INFORMATIONAL PURPOSES ONLY AND DO NOT CONSTITUTE REPRESENTATIONS OR WARRANTIES. THESE SPECIFICATIONS ARE SUBJECT TO BUYER'S INDEPENDENT VERIFICATION UPON INSPECTION.
THE AIRCRAFT IS SUBJECT TO PRIOR SALE, LEASE AND/OR REMOVAL FROM THE MARKET WITHOUT PRIOR NOTICE. AUGUST 24, 2023 2:16 PM

AVPROJETS.COM
info@avprojets.com

900 Bestgate Road Suite 412 Annapolis, MD 21401
+1.410.573.1515

Anderson Bell
abell@avprojets.com

1988 Gulfstream IV SN 1074 N995GG



SPECIFICATIONS ARE PROVIDED FOR INFORMATIONAL PURPOSES ONLY AND DO NOT CONSTITUTE REPRESENTATIONS OR WARRANTIES. THESE SPECIFICATIONS ARE SUBJECT TO BUYER'S INDEPENDENT VERIFICATION UPON INSPECTION.
THE AIRCRAFT IS SUBJECT TO PRIOR SALE, LEASE AND/OR REMOVAL FROM THE MARKET WITHOUT PRIOR NOTICE. AUGUST 24, 2023 2:16 PM

AVPROJETS.COM
info@avprojets.com

900 Bestgate Road Suite 412 Annapolis, MD 21401
+1.410.573.1515

Anderson Bell
abell@avprojets.com

1988 Gulfstream IV SN 1074 N995GG



SPECIFICATIONS ARE PROVIDED FOR INFORMATIONAL PURPOSES ONLY AND DO NOT CONSTITUTE REPRESENTATIONS OR WARRANTIES. THESE SPECIFICATIONS ARE SUBJECT TO BUYER'S INDEPENDENT VERIFICATION UPON INSPECTION.
THE AIRCRAFT IS SUBJECT TO PRIOR SALE, LEASE AND/OR REMOVAL FROM THE MARKET WITHOUT PRIOR NOTICE. AUGUST 24, 2023 2:16 PM

AVPROJETS.COM
info@avprojets.com

900 Bestgate Road Suite 412 Annapolis, MD 21401
+1.410.573.1515

Anderson Bell
abell@avprojets.com

1988 Gulfstream IV SN 1074 N995GG



SPECIFICATIONS ARE PROVIDED FOR INFORMATIONAL PURPOSES ONLY AND DO NOT CONSTITUTE REPRESENTATIONS OR WARRANTIES. THESE SPECIFICATIONS ARE SUBJECT TO BUYER'S INDEPENDENT VERIFICATION UPON INSPECTION.
THE AIRCRAFT IS SUBJECT TO PRIOR SALE, LEASE AND/OR REMOVAL FROM THE MARKET WITHOUT PRIOR NOTICE. AUGUST 24, 2023 2:16 PM

AVPROJETS.COM
info@avprojets.com

900 Bestgate Road Suite 412 Annapolis, MD 21401
+1.410.573.1515

Anderson Bell
abell@avprojets.com

1988 Gulfstream IV SN 1074 N995GG



SPECIFICATIONS ARE PROVIDED FOR INFORMATIONAL PURPOSES ONLY AND DO NOT CONSTITUTE REPRESENTATIONS OR WARRANTIES. THESE SPECIFICATIONS ARE SUBJECT TO BUYER'S INDEPENDENT VERIFICATION UPON INSPECTION.
THE AIRCRAFT IS SUBJECT TO PRIOR SALE, LEASE AND/OR REMOVAL FROM THE MARKET WITHOUT PRIOR NOTICE. AUGUST 24, 2023 2:16 PM

AVPROJETS.COM
info@avprojets.com

900 Bestgate Road Suite 412 Annapolis, MD 21401
+1.410.573.1515

Anderson Bell
abell@avprojets.com

1988 Gulfstream IV SN 1074 N995GG



SPECIFICATIONS ARE PROVIDED FOR INFORMATIONAL PURPOSES ONLY AND DO NOT CONSTITUTE REPRESENTATIONS OR WARRANTIES. THESE SPECIFICATIONS ARE SUBJECT TO BUYER'S INDEPENDENT VERIFICATION UPON INSPECTION.
THE AIRCRAFT IS SUBJECT TO PRIOR SALE, LEASE AND/OR REMOVAL FROM THE MARKET WITHOUT PRIOR NOTICE. AUGUST 24, 2023 2:16 PM

AVPROJETS.COM
info@avprojets.com

900 Bestgate Road Suite 412 Annapolis, MD 21401
+1.410.573.1515

Anderson Bell
abell@avprojets.com

1988 Gulfstream IV SN 1074 N995GG



SPECIFICATIONS ARE PROVIDED FOR INFORMATIONAL PURPOSES ONLY AND DO NOT CONSTITUTE REPRESENTATIONS OR WARRANTIES. THESE SPECIFICATIONS ARE SUBJECT TO BUYER'S INDEPENDENT VERIFICATION UPON INSPECTION.
THE AIRCRAFT IS SUBJECT TO PRIOR SALE, LEASE AND/OR REMOVAL FROM THE MARKET WITHOUT PRIOR NOTICE. AUGUST 24, 2023 2:16 PM

AVPROJETS.COM
info@avprojets.com

900 Bestgate Road Suite 412 Annapolis, MD 21401
+1.410.573.1515

Anderson Bell
abell@avprojets.com

1988 Gulfstream IV SN 1074 N995GG



SPECIFICATIONS ARE PROVIDED FOR INFORMATIONAL PURPOSES ONLY AND DO NOT CONSTITUTE REPRESENTATIONS OR WARRANTIES. THESE SPECIFICATIONS ARE SUBJECT TO BUYER'S INDEPENDENT VERIFICATION UPON INSPECTION.
THE AIRCRAFT IS SUBJECT TO PRIOR SALE, LEASE AND/OR REMOVAL FROM THE MARKET WITHOUT PRIOR NOTICE. AUGUST 24, 2023 2:16 PM

AVPROJETS.COM
info@avprojets.com

900 Bestgate Road Suite 412 Annapolis, MD 21401
+1.410.573.1515

Anderson Bell
abell@avprojets.com

1988 Gulfstream IV SN 1074 N995GG



SPECIFICATIONS ARE PROVIDED FOR INFORMATIONAL PURPOSES ONLY AND DO NOT CONSTITUTE REPRESENTATIONS OR WARRANTIES. THESE SPECIFICATIONS ARE SUBJECT TO BUYER'S INDEPENDENT VERIFICATION UPON INSPECTION. THE AIRCRAFT IS SUBJECT TO PRIOR SALE, LEASE AND/OR REMOVAL FROM THE MARKET WITHOUT PRIOR NOTICE. AUGUST 24, 2023 2:16 PM

AVPROJETS.COM
info@avprojets.com

900 Bestgate Road Suite 412 Annapolis, MD 21401
+1.410.573.1515

Anderson Bell
abell@avprojets.com

1988 Gulfstream IV SN 1074 N995GG



SPECIFICATIONS ARE PROVIDED FOR INFORMATIONAL PURPOSES ONLY AND DO NOT CONSTITUTE REPRESENTATIONS OR WARRANTIES. THESE SPECIFICATIONS ARE SUBJECT TO BUYER'S INDEPENDENT VERIFICATION UPON INSPECTION.
THE AIRCRAFT IS SUBJECT TO PRIOR SALE, LEASE AND/OR REMOVAL FROM THE MARKET WITHOUT PRIOR NOTICE. AUGUST 24, 2023 2:16 PM

AVPROJETS.COM
info@avprojets.com

900 Bestgate Road Suite 412 Annapolis, MD 21401
+1.410.573.1515

Anderson Bell
abell@avprojets.com

1988 Gulfstream IV SN 1074 N995GG



SPECIFICATIONS ARE PROVIDED FOR INFORMATIONAL PURPOSES ONLY AND DO NOT CONSTITUTE REPRESENTATIONS OR WARRANTIES. THESE SPECIFICATIONS ARE SUBJECT TO BUYER'S INDEPENDENT VERIFICATION UPON INSPECTION.
THE AIRCRAFT IS SUBJECT TO PRIOR SALE, LEASE AND/OR REMOVAL FROM THE MARKET WITHOUT PRIOR NOTICE. AUGUST 24, 2023 2:16 PM

AVPROJETS.COM
info@avprojets.com

900 Bestgate Road Suite 412 Annapolis, MD 21401
+1.410.573.1515

Anderson Bell
abell@avprojets.com

1988 Gulfstream IV SN 1074 N995GG



SPECIFICATIONS ARE PROVIDED FOR INFORMATIONAL PURPOSES ONLY AND DO NOT CONSTITUTE REPRESENTATIONS OR WARRANTIES. THESE SPECIFICATIONS ARE SUBJECT TO BUYER'S INDEPENDENT VERIFICATION UPON INSPECTION.
THE AIRCRAFT IS SUBJECT TO PRIOR SALE, LEASE AND/OR REMOVAL FROM THE MARKET WITHOUT PRIOR NOTICE. AUGUST 24, 2023 2:16 PM

AVPROJETS.COM
info@avprojets.com

900 Bestgate Road Suite 412 Annapolis, MD 21401
+1.410.573.1515

Anderson Bell
abell@avprojets.com

1988 Gulfstream IV SN 1074 N995GG



SPECIFICATIONS ARE PROVIDED FOR INFORMATIONAL PURPOSES ONLY AND DO NOT CONSTITUTE REPRESENTATIONS OR WARRANTIES. THESE SPECIFICATIONS ARE SUBJECT TO BUYER'S INDEPENDENT VERIFICATION UPON INSPECTION. THE AIRCRAFT IS SUBJECT TO PRIOR SALE, LEASE AND/OR REMOVAL FROM THE MARKET WITHOUT PRIOR NOTICE. AUGUST 24, 2023 2:16 PM

1988 Gulfstream IV SN 1074 N995GG



SPECIFICATIONS ARE PROVIDED FOR INFORMATIONAL PURPOSES ONLY AND DO NOT CONSTITUTE REPRESENTATIONS OR WARRANTIES. THESE SPECIFICATIONS ARE SUBJECT TO BUYER'S INDEPENDENT VERIFICATION UPON INSPECTION. THE AIRCRAFT IS SUBJECT TO PRIOR SALE, LEASE AND/OR REMOVAL FROM THE MARKET WITHOUT PRIOR NOTICE. AUGUST 24, 2023 2:16 PM

AVPROJETS.COM
info@avprojets.com

900 Bestgate Road Suite 412 Annapolis, MD 21401
+1.410.573.1515

Anderson Bell
abell@avprojets.com



AVPRO INC.

CELEBRATING OVER **30** YEARS OF EXCELLENCE

We perform for our clients, averaging two transactions a week.

We match aircraft to your specifications in a professional and timely manner, allowing you to concentrate on your business, leaving the important details of marketing, market research, negotiating and contracting to us.

Avpro offers aircraft financing advisory services. We have the expertise to navigate the appropriate structure, costs and terms to help you meet your objectives. We are ready to provide advice, analysis and sourcing of the lender best suited to meet your requirements.

SERVING CUSTOMERS
AROUND THE GLOBE

Talk to Us info@avprojets.com +1.410.573.1515

Connect with Us LINKEDIN FACEBOOK TWITTER INSTAGRAM

