

1984 Make SN 50-085

Falcon 50

N107CV



EXECUTIVE SALES DIRECTOR

Herbie Kane

hkane@avprojets.com

+1.410.573.1515

AVPRO INC.
www.avprojets.com

1984 Falcon 50 SN 50-085 N107CV

Aircraft Listing Details:

Total Hours: 11,838
Total Landings: 6,907

Engines: Honeywell TFE-731-3D-1C with N1 DEEC's

New Turbine Blades (Engines #1 & #3)

	#1	#2	#3
Total Hours:	11,729	11,734	11,684
Engine Cycles:	6,707	6,693	6,675
Time Since OH:	0	986	0
Serial Numbers:	P-76363	P-76397	P-76378

APU: Sundstrand Solar T-60T-40C03A1

Total Hours: 4,550
Total Cycles: 6,350
Serial Number: SP-E945052

Aircraft Highlights:

- 1C Inspection c/w Aug. 2023 Atlantic Aviation, Westfield MA
- Dry Bay Mod Completed
- Superior Engine Overhaul Status
- No Damage History, Always Hangared
- Honeywell -3D Engine Modifications
- N1 DEEC Engine Computers
- Gogo Biz ATG-5000 Wi-Fi
- Engines on Honeywell MSP Gold Since New

Avionics:

- Collins Proline II
- Five (5) Tube EFIS-86C
- Collins APS-85 Digital Auto Pilot/Flight Director/IFCS
- Triple Collins VHF-22B Comms w/8.33 Spacing
- Dual Collins VIR-32A Navs w/FM Immunity
- Dual Collins ADF-60 ADFs
- Dual Collins DME-42 DMEs
- Dual Collins TDR-94D Transponders w/Elementary Flight ID & Enhanced Surveillance
- Dual Global XLS FMS w/GPS
- Single Honeywell Laseref II Navigation Unit
- Dual Collins ADS-82C Air Data Computers
- Dual Collins RMI-36 Radio Magnetic Indicators
- Collins ALT-55B Radar Altimeter
- Collins TWR-850 Color Weather Radar
- Dual Bendix-King KHF-950 HF Radios with SELCAL
- Honeywell TCAS II w/ Change 7.0
- Honeywell Mark V Class A (TAWS-A)
- Fairchild A100A Cockpit Voice Recorder
- Artex 406 MHz ELT

SPECIFICATIONS ARE PROVIDED FOR INFORMATIONAL PURPOSES ONLY AND DO NOT CONSTITUTE REPRESENTATIONS OR WARRANTIES. THESE SPECIFICATIONS ARE SUBJECT TO BUYER'S INDEPENDENT VERIFICATION UPON INSPECTION.
THE AIRCRAFT IS SUBJECT TO PRIOR SALE, LEASE AND/OR REMOVAL FROM THE MARKET WITHOUT PRIOR NOTICE. OCTOBER 10, 2024 3:23 PM

1984 Falcon 50 SN 50-085 N107CV

Connectivity:

- Gogo Biz ATG-5000 Wi-Fi
 - Iridium Flight Phone
-

Entertainment:

- Cabin Entertainment System
 - Airshow Cabin Display
 - Forward 14" Bulkhead Monitor
-

Maintenance Programs:

- Engines on Honeywell MSP Gold Since New
 - Flight Docs Computerized Maintenance Tracking
-

Navigation Compliance:

- ADS-B Accomplished 2018 by West Star STC
- 8.33 Spacing
- FM Immunity
- RVSM Compliant

Features/Options:

- N1 DEEC Engine Computers
 - Honeywell -3D Engine Modifications
 - Cockpit Jump Seat
 - Large External Baggage Compartment
 - Dual Fold Down Executive Tables
 - Coffee Maker
-

Interior: (2008 Refurbishment)

Nine (9) Passenger Fireblocked Interior Offering a Full Service Galley.

- Forward Four (4) Place Club
 - Aft Two (2) Place Club Opposite a Three (3) Place Divan
 - Pull-Out Executive Tables
 - Aft Passenger Lavatory
 - Gold Colored Plating
 - Medium Toned Burlwood Veneer
 - Pearl Leather Seating
-

Exterior: (2006 Paint)

Overall White with Las Vegas Gold & Dark Green Accent Striping.

SPECIFICATIONS ARE PROVIDED FOR INFORMATIONAL PURPOSES ONLY AND DO NOT CONSTITUTE REPRESENTATIONS OR WARRANTIES. THESE SPECIFICATIONS ARE SUBJECT TO BUYER'S INDEPENDENT VERIFICATION UPON INSPECTION.
THE AIRCRAFT IS SUBJECT TO PRIOR SALE, LEASE AND/OR REMOVAL FROM THE MARKET WITHOUT PRIOR NOTICE. OCTOBER 10, 2024 3:23 PM

1984 Falcon 50 SN 50-085 N107CV



SPECIFICATIONS ARE PROVIDED FOR INFORMATIONAL PURPOSES ONLY AND DO NOT CONSTITUTE REPRESENTATIONS OR WARRANTIES. THESE SPECIFICATIONS ARE SUBJECT TO BUYER'S INDEPENDENT VERIFICATION UPON INSPECTION.
THE AIRCRAFT IS SUBJECT TO PRIOR SALE, LEASE AND/OR REMOVAL FROM THE MARKET WITHOUT PRIOR NOTICE. OCTOBER 10, 2024 3:23 PM

AVPROJETS.COM
info@avprojets.com

900 Bestgate Road Suite 412 Annapolis, MD 21401
+1.410.573.1515

Herbie Kane
hkane@avprojets.com

1984 Falcon 50 SN 50-085 N107CV



SPECIFICATIONS ARE PROVIDED FOR INFORMATIONAL PURPOSES ONLY AND DO NOT CONSTITUTE REPRESENTATIONS OR WARRANTIES. THESE SPECIFICATIONS ARE SUBJECT TO BUYER'S INDEPENDENT VERIFICATION UPON INSPECTION.
THE AIRCRAFT IS SUBJECT TO PRIOR SALE, LEASE AND/OR REMOVAL FROM THE MARKET WITHOUT PRIOR NOTICE. OCTOBER 10, 2024 3:23 PM

AVPROJETS.COM
info@avprojets.com

900 Bestgate Road Suite 412 Annapolis, MD 21401
+1.410.573.1515

Herbie Kane
hkane@avprojets.com

1984 Falcon 50 SN 50-085 N107CV



SPECIFICATIONS ARE PROVIDED FOR INFORMATIONAL PURPOSES ONLY AND DO NOT CONSTITUTE REPRESENTATIONS OR WARRANTIES. THESE SPECIFICATIONS ARE SUBJECT TO BUYER'S INDEPENDENT VERIFICATION UPON INSPECTION.
THE AIRCRAFT IS SUBJECT TO PRIOR SALE, LEASE AND/OR REMOVAL FROM THE MARKET WITHOUT PRIOR NOTICE. OCTOBER 10, 2024 3:23 PM

AVPROJETS.COM
info@avprojets.com

900 Bestgate Road Suite 412 Annapolis, MD 21401
+1.410.573.1515

Herbie Kane
hkane@avprojets.com

1984 Falcon 50 SN 50-085 N107CV



SPECIFICATIONS ARE PROVIDED FOR INFORMATIONAL PURPOSES ONLY AND DO NOT CONSTITUTE REPRESENTATIONS OR WARRANTIES. THESE SPECIFICATIONS ARE SUBJECT TO BUYER'S INDEPENDENT VERIFICATION UPON INSPECTION.
THE AIRCRAFT IS SUBJECT TO PRIOR SALE, LEASE AND/OR REMOVAL FROM THE MARKET WITHOUT PRIOR NOTICE. OCTOBER 10, 2024 3:23 PM

AVPROJETS.COM
info@avprojets.com

900 Bestgate Road Suite 412 Annapolis, MD 21401
+1.410.573.1515

Herbie Kane
hkane@avprojets.com

1984 Falcon 50 SN 50-085 N107CV



SPECIFICATIONS ARE PROVIDED FOR INFORMATIONAL PURPOSES ONLY AND DO NOT CONSTITUTE REPRESENTATIONS OR WARRANTIES. THESE SPECIFICATIONS ARE SUBJECT TO BUYER'S INDEPENDENT VERIFICATION UPON INSPECTION.
THE AIRCRAFT IS SUBJECT TO PRIOR SALE, LEASE AND/OR REMOVAL FROM THE MARKET WITHOUT PRIOR NOTICE. OCTOBER 10, 2024 3:23 PM

AVPROJETS.COM
info@avprojets.com

900 Bestgate Road Suite 412 Annapolis, MD 21401
+1.410.573.1515

Herbie Kane
hkane@avprojets.com

1984 Falcon 50 SN 50-085 N107CV



SPECIFICATIONS ARE PROVIDED FOR INFORMATIONAL PURPOSES ONLY AND DO NOT CONSTITUTE REPRESENTATIONS OR WARRANTIES. THESE SPECIFICATIONS ARE SUBJECT TO BUYER'S INDEPENDENT VERIFICATION UPON INSPECTION.
THE AIRCRAFT IS SUBJECT TO PRIOR SALE, LEASE AND/OR REMOVAL FROM THE MARKET WITHOUT PRIOR NOTICE. OCTOBER 10, 2024 3:23 PM

AVPROJETS.COM
info@avprojets.com

900 Bestgate Road Suite 412 Annapolis, MD 21401
+1.410.573.1515

Herbie Kane
hkane@avprojets.com

1984 Falcon 50 SN 50-085 N107CV



SPECIFICATIONS ARE PROVIDED FOR INFORMATIONAL PURPOSES ONLY AND DO NOT CONSTITUTE REPRESENTATIONS OR WARRANTIES. THESE SPECIFICATIONS ARE SUBJECT TO BUYER'S INDEPENDENT VERIFICATION UPON INSPECTION.
THE AIRCRAFT IS SUBJECT TO PRIOR SALE, LEASE AND/OR REMOVAL FROM THE MARKET WITHOUT PRIOR NOTICE. OCTOBER 10, 2024 3:23 PM

AVPROJETS.COM
info@avprojets.com

900 Bestgate Road Suite 412 Annapolis, MD 21401
+1.410.573.1515

Herbie Kane
hkane@avprojets.com

1984 Falcon 50 SN 50-085 N107CV



SPECIFICATIONS ARE PROVIDED FOR INFORMATIONAL PURPOSES ONLY AND DO NOT CONSTITUTE REPRESENTATIONS OR WARRANTIES. THESE SPECIFICATIONS ARE SUBJECT TO BUYER'S INDEPENDENT VERIFICATION UPON INSPECTION.
THE AIRCRAFT IS SUBJECT TO PRIOR SALE, LEASE AND/OR REMOVAL FROM THE MARKET WITHOUT PRIOR NOTICE. OCTOBER 10, 2024 3:23 PM

AVPROJETS.COM
info@avprojets.com

900 Bestgate Road Suite 412 Annapolis, MD 21401
+1.410.573.1515

Herbie Kane
hkane@avprojets.com



AVPRO INC.

CELEBRATING OVER **30** YEARS OF EXCELLENCE

We perform for our clients, averaging two transactions a week.

We match aircraft to your specifications in a professional and timely manner, allowing you to concentrate on your business, leaving the important details of marketing, market research, negotiating and contracting to us.

Avpro offers aircraft financing advisory services. We have the expertise to navigate the appropriate structure, costs and terms to help you meet your objectives. We are ready to provide advice, analysis and sourcing of the lender best suited to meet your requirements.

SERVING CUSTOMERS
AROUND THE GLOBE

Talk to Us

info@avprojets.com

+1.410.573.1515

Connect with Us



1984 Falcon 50 SN 50-085 N107CV

The Dassault Falcon 50 is a super-midsize, long-range business jet produced by Dassault Aviation in France. The first prototype took flight on November 7, 1976, and the jet received French airworthiness certification on February 27, 1979, followed by U.S. FAA certification on March 7, 1979.

The Falcon 50 was the world's first civil aircraft to feature supercritical wings. Its range and payload capacity remain impressive even today, capable of carrying eight passengers 3,020 miles (2,625 nautical miles) at a speed of Mach 0.80. The Falcon 50's versatility, capability for short-field landings, and over 3,200 nautical mile range made it one of the most successful production series aircraft ever developed.



Performance

Max Speed..... 570 kts.
Max Range..... 3,150 nm
Balanced Field Length 4,700 ft.
Landing Field Length... 2,900 ft.
Max Cruise Altitude..... 45,000 ft.

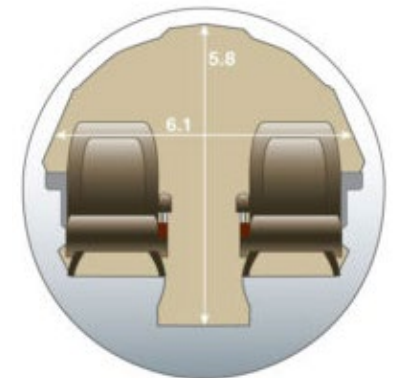
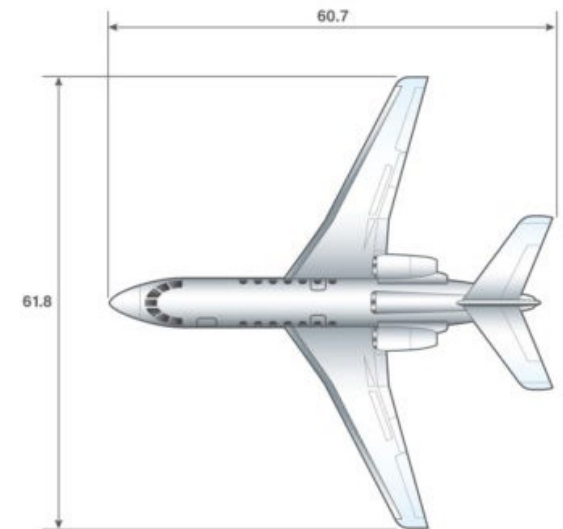

SPECIFICATIONS ARE PROVIDED FOR INFORMATIONAL PURPOSES ONLY AND DO NOT CONSTITUTE REPRESENTATIONS OR WARRANTIES. THESE SPECIFICATIONS ARE SUBJECT TO BUYER'S INDEPENDENT VERIFICATION UPON INSPECTION.
THE AIRCRAFT IS SUBJECT TO PRIOR SALE, LEASE AND/OR REMOVAL FROM THE MARKET WITHOUT PRIOR NOTICE. OCTOBER 10, 2024 3:23 PM