

2001 Dassault SN 151
Falcon 2000



EXECUTIVE SALES DIRECTOR

Herbie Kane
hkan@avprojets.com
+1.410.573.1515

AVPRO INC.
www.avprojets.com

2001 Dassault Falcon 2000 SN 151 N500MA

Aircraft Listing Details:

Total Hours: 6773
Total Landings: 4411

Engines: Honeywell CFE 738-1-1B

	#1	#2
Total Hours:	6596	6596
Engine Cycles:	4297	4297
Serial Numbers:	P105456	P105437

APU: Honeywell GTCP36-150 (F2M)

Total Hours: 4700
Serial Number: P-261

Aircraft Highlights:

- US Registered with Excellent Pedigree
- Preferred 10 Passenger Interior Configuration
- 1C/3C Inspections by Standard Aero, Sept 2019
- Paint & Interior by Duncan Aviation, June 2013
- ATG-4000 GoGo Wi-Fi with Talk & Text
- Engines & APU on MSP Gold

Avionics:

- Collins Pro Line 4 Avionics Suite
- Collins EFIS-4000 4-Tube EFIS/Flight Director
- Collins APS-4000 Autopilot
- Dual Collins VHF-422C Comms w/8.33 Spacing
- Dual Collins VIR-432 Navs w/FM Immunity
- Dual Collins DME-442 DMEs
- Dual Collins ADF-462 ADFs
- Dual Collins ADC-850C Air Data Computers
- Dual Collins RTU-4220 Radio Tuning Units
- Dual Collins TDR-94D Mode S Transponders w/Enhanced Flight ID
- Dual Collins FMS-6100 FMS
- Dual Collins GPS-4000S (New Sept 2019)
- Dual Honeywell LASEREF IV IRS
- Dual Collins HF-9000 HFs w/Coltech CSD-714 SELCAL
- Collins AHS-85E Altitude Heading Reference System
- Collins ALT-55B Radar Altimeter
- Collins WXR-850 Weather Radar
- Honeywell Mark V EGPWS w/Windshear Alert
- Collins TCAS-4000 w/Change 7.1
- Honeywell SS Cockpit Voice Recorder (120 minute)
- Honeywell SS Flight Data Recorder
- Socata ELT96A 406 MHz ELT
- Dual Baker M1045 Audio Panels
- Dual Baker M1050 PA/Chime

SPECIFICATIONS ARE PROVIDED FOR INFORMATIONAL PURPOSES ONLY AND DO NOT CONSTITUTE REPRESENTATIONS OR WARRANTIES. THESE SPECIFICATIONS ARE SUBJECT TO BUYER'S INDEPENDENT VERIFICATION UPON INSPECTION.
THE AIRCRAFT IS SUBJECT TO PRIOR SALE, LEASE AND/OR REMOVAL FROM THE MARKET WITHOUT PRIOR NOTICE. OCTOBER 31, 2024 12:58 PM

2001 Dassault Falcon 2000 SN 151 N500MA

Connectivity:

- Aircell ST-3100 Iridium SATCOM
 - Aircell ATG-4000 GoGo Wi-Fi w/ Talk & Text
-

Entertainment:

- Audio International Cabin Management System
 - Airshow Genesys
 - Dual DVD Players
 - One (1) 18" Forward Bulkhead Monitor
 - Four (4) Rosen 8.4" Side-Ledge LCD Monitors
 - Auxiliary 115V AC 60 Hz Power
(6 outlets: 1 cockpit, 1 galley, 4 cabin)
-

Maintenance Programs:

- Engines Enrolled on Honeywell MSP Gold
 - APU Enrolled on Honeywell MSP Gold
 - CAMP Maintenance Tracking Program
-

Ops / Navigation Compliance:

- Part 135 Operated
- JAR-OPS Approved
- ADS-B Out
- Collins TCAS-4000 w/Change 7.1
- 8.33 Spacing & FM Immunity
- MNPS with RNP10 (NAT HLA)

Inspection Status:

- 1C/3C Inspections by Standard Aero-Houston, September 2019
- 2C Inspection & Gear OH by Duncan Avtn-Lincoln, July 2013
- Dry Bay Mod by Dassault-Little Rock, May 2013

Inspection	Complied With	Next Due
12 Mo/800 hrs	Oct 2023	Oct 2024
24 Mo/1600 hrs	Oct 2023	Oct 2025
36 Mo/2400 hrs	Sept 2022	Sept 2025
12 Month	Oct 2023	Oct 2024
24 Month	Oct 2023	Oct 2025
36 Month	Sept 2022	Sept 2025
1B (1600 hrs)	Mar 2021@5,933 hrs	7,515 hrs
2B (3200 hrs)	Mar 2021@5,933 hrs	9,115 hrs
3B (4800 hrs)	Feb 2017@4,372 hrs	9,115 hrs
1C (72 Mo/3750 Idgs)	Sep 2019@3,576 Idgs	Sep 2025 / 7,326 Idgs
2C (144 Mo/7500 Idgs)	Jun 2013@2,672 Idgs	Sep 2025 / 10,172 Idgs

Weights:

Max Ramp	36,700 lbs.
Max Take Off	36,500 lbs.
Max Landing	34,500 lbs.
Empty	22,217 lbs.
BOW	23,188 lbs.
Max Zero Fuel	28,660 lbs.

SPECIFICATIONS ARE PROVIDED FOR INFORMATIONAL PURPOSES ONLY AND DO NOT CONSTITUTE REPRESENTATIONS OR WARRANTIES. THESE SPECIFICATIONS ARE SUBJECT TO BUYER'S INDEPENDENT VERIFICATION UPON INSPECTION.
THE AIRCRAFT IS SUBJECT TO PRIOR SALE, LEASE AND/OR REMOVAL FROM THE MARKET WITHOUT PRIOR NOTICE. OCTOBER 31, 2024 12:58 PM

2001 Dassault Falcon 2000 SN 151 N500MA

Features/Options:

- Dual Davtron M877 Clocks
- Meggitt ISFD Standby Instrument
- Smiths Standby Magnetic Compass
- Two (2) Rechargeable Flight Deck Flashlights
- Sunscreens for Front & Side Cockpit Windows
- ERDA 3rd Flight Deck Seat
- Two (2) Pilot Oxygen Masks (half-face)
w/Separate Smoke Goggles
- Therapeutic Portable Oxygen System
- Microwave Oven
- High Temperature Oven
- Coffee Maker
- Galley Pocket Sliding Door
- Remote Cabin Temperature Control System
- Manual Window Shades
- Fold Down Shelf in Aft Baggage Compartment
- Meggitt Flight Display w/ XL-245 Securaplane Battery
- Concorde Sealed Lead Acid Battery (SB F2000-192) Upgrade
- Dual LED Nav Lights
- Pylon Lights
- Teleflex Recognition Light System
- Crash Axe w/ Storage
- On-Board Telescoping Tow Bar

Interior:

Refurbished by Duncan Aviation-Lincoln, June 2013
New Carpet by GAMA-FXE, February 2020

Beautiful ten (10) passenger executive interior featuring a four-place club arrangement in the forward cabin, followed by a four-place conference/dining group with table opposite a two-place club in the aft cabin. The cabin is completed in luxurious beige leather seats accented by earth tone lower sidewalls and carpet throughout. The cream ultraleather headliner and upper sidewalls allow for a bright and open cabin feel. The cabinetry is finished in rich Walnut high-gloss woodwork and complimented by tasteful soft gold colored plating.

The forward 46" galley is optioned with a left-hand crew closet and is fully equipped to include ice/cold chests, ample storage, high temperature oven, microwave oven, and coffee maker. A full-size galley pocket door separates the cabin for improved privacy and a quieter passenger experience. The 3rd flight deck seat (ERDA) also has a storage drawer.

The fully enclosed, private lavatory is in the aft cabin with a full vanity and electric flushing toilet that is serviced externally. The spacious baggage compartment with fold down hanger bar is accessible in-flight through a mirrored door in the back of the lav.

Exterior:

New Paint by Duncan Aviation-Lincoln, June 2013
Overall White w/Blue & Red Accent Striping.

SPECIFICATIONS ARE PROVIDED FOR INFORMATIONAL PURPOSES ONLY AND DO NOT CONSTITUTE REPRESENTATIONS OR WARRANTIES. THESE SPECIFICATIONS ARE SUBJECT TO BUYER'S INDEPENDENT VERIFICATION UPON INSPECTION.
THE AIRCRAFT IS SUBJECT TO PRIOR SALE, LEASE AND/OR REMOVAL FROM THE MARKET WITHOUT PRIOR NOTICE. OCTOBER 31, 2024 12:58 PM

2001 Dassault Falcon 2000 SN 151 N500MA

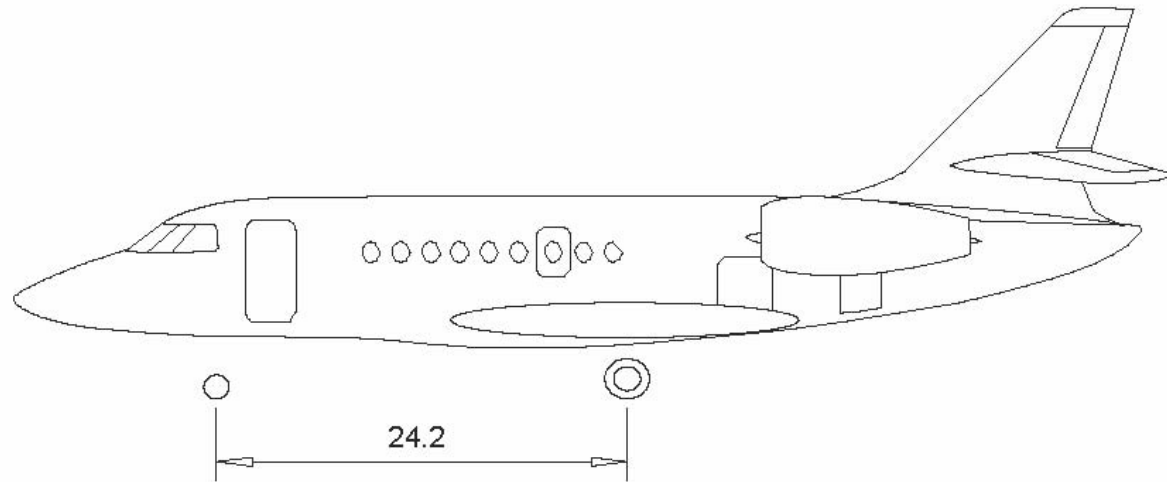
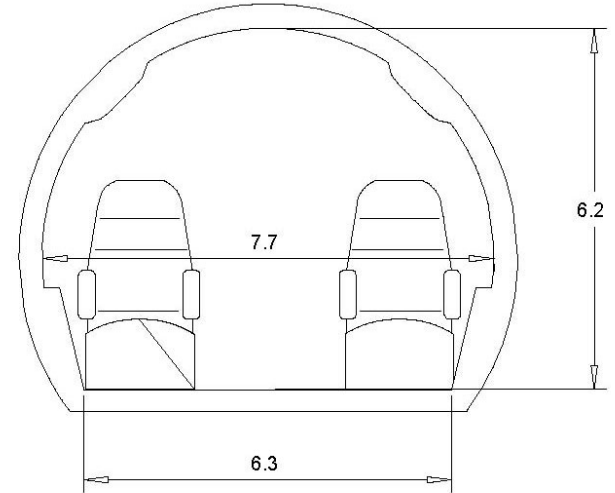
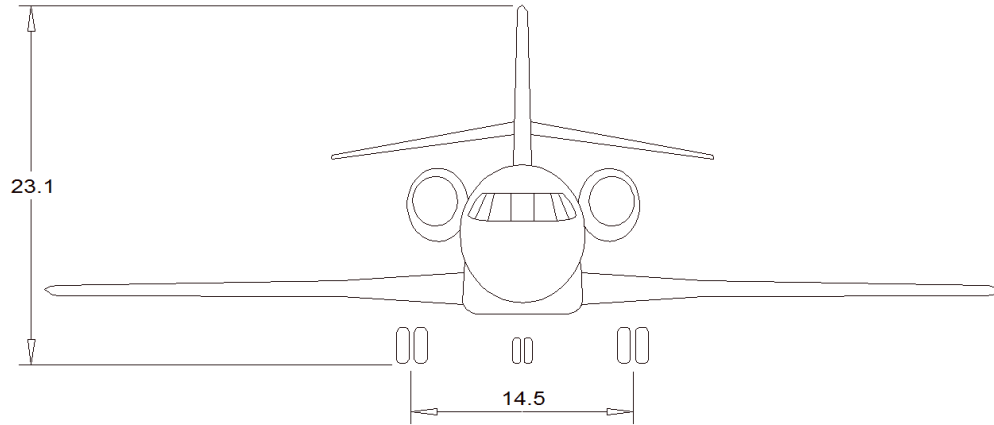

SPECIFICATIONS ARE PROVIDED FOR INFORMATIONAL PURPOSES ONLY AND DO NOT CONSTITUTE REPRESENTATIONS OR WARRANTIES. THESE SPECIFICATIONS ARE SUBJECT TO BUYER'S INDEPENDENT VERIFICATION UPON INSPECTION.
THE AIRCRAFT IS SUBJECT TO PRIOR SALE, LEASE AND/OR REMOVAL FROM THE MARKET WITHOUT PRIOR NOTICE. OCTOBER 31, 2024 12:58 PM

2001 Dassault Falcon 2000 SN 151 N500MA



SPECIFICATIONS ARE PROVIDED FOR INFORMATIONAL PURPOSES ONLY AND DO NOT CONSTITUTE REPRESENTATIONS OR WARRANTIES. THESE SPECIFICATIONS ARE SUBJECT TO BUYER'S INDEPENDENT VERIFICATION UPON INSPECTION.
THE AIRCRAFT IS SUBJECT TO PRIOR SALE, LEASE AND/OR REMOVAL FROM THE MARKET WITHOUT PRIOR NOTICE. OCTOBER 31, 2024 12:58 PM

AVPROJETS.COM
info@avprojets.com

900 Bestgate Road Suite 412 Annapolis, MD 21401
+1.410.573.1515

Herbie Kane
hkane@avprojets.com

2001 Dassault Falcon 2000 SN 151 N500MA



SPECIFICATIONS ARE PROVIDED FOR INFORMATIONAL PURPOSES ONLY AND DO NOT CONSTITUTE REPRESENTATIONS OR WARRANTIES. THESE SPECIFICATIONS ARE SUBJECT TO BUYER'S INDEPENDENT VERIFICATION UPON INSPECTION.
THE AIRCRAFT IS SUBJECT TO PRIOR SALE, LEASE AND/OR REMOVAL FROM THE MARKET WITHOUT PRIOR NOTICE. OCTOBER 31, 2024 12:58 PM

AVPROJETS.COM
info@avprojets.com

900 Bestgate Road Suite 412 Annapolis, MD 21401
+1.410.573.1515

Herbie Kane
hkane@avprojets.com

2001 Dassault Falcon 2000 SN 151 N500MA



SPECIFICATIONS ARE PROVIDED FOR INFORMATIONAL PURPOSES ONLY AND DO NOT CONSTITUTE REPRESENTATIONS OR WARRANTIES. THESE SPECIFICATIONS ARE SUBJECT TO BUYER'S INDEPENDENT VERIFICATION UPON INSPECTION.
THE AIRCRAFT IS SUBJECT TO PRIOR SALE, LEASE AND/OR REMOVAL FROM THE MARKET WITHOUT PRIOR NOTICE. OCTOBER 31, 2024 12:58 PM

AVPROJETS.COM
info@avprojets.com

900 Bestgate Road Suite 412 Annapolis, MD 21401
+1.410.573.1515

Herbie Kane
hkane@avprojets.com

2001 Dassault Falcon 2000 SN 151 N500MA



SPECIFICATIONS ARE PROVIDED FOR INFORMATIONAL PURPOSES ONLY AND DO NOT CONSTITUTE REPRESENTATIONS OR WARRANTIES. THESE SPECIFICATIONS ARE SUBJECT TO BUYER'S INDEPENDENT VERIFICATION UPON INSPECTION.
THE AIRCRAFT IS SUBJECT TO PRIOR SALE, LEASE AND/OR REMOVAL FROM THE MARKET WITHOUT PRIOR NOTICE. OCTOBER 31, 2024 12:58 PM

AVPROJETS.COM
info@avprojets.com

900 Bestgate Road Suite 412 Annapolis, MD 21401
+1.410.573.1515

Herbie Kane
hkane@avprojets.com

2001 Dassault Falcon 2000 SN 151 N500MA



SPECIFICATIONS ARE PROVIDED FOR INFORMATIONAL PURPOSES ONLY AND DO NOT CONSTITUTE REPRESENTATIONS OR WARRANTIES. THESE SPECIFICATIONS ARE SUBJECT TO BUYER'S INDEPENDENT VERIFICATION UPON INSPECTION.
THE AIRCRAFT IS SUBJECT TO PRIOR SALE, LEASE AND/OR REMOVAL FROM THE MARKET WITHOUT PRIOR NOTICE. OCTOBER 31, 2024 12:58 PM

AVPROJETS.COM
info@avprojets.com

900 Bestgate Road Suite 412 Annapolis, MD 21401
+1.410.573.1515

Herbie Kane
hkane@avprojets.com

2001 Dassault Falcon 2000 SN 151 N500MA



SPECIFICATIONS ARE PROVIDED FOR INFORMATIONAL PURPOSES ONLY AND DO NOT CONSTITUTE REPRESENTATIONS OR WARRANTIES. THESE SPECIFICATIONS ARE SUBJECT TO BUYER'S INDEPENDENT VERIFICATION UPON INSPECTION. THE AIRCRAFT IS SUBJECT TO PRIOR SALE, LEASE AND/OR REMOVAL FROM THE MARKET WITHOUT PRIOR NOTICE. OCTOBER 31, 2024 12:58 PM

AVPROJETS.COM
info@avprojets.com

900 Bestgate Road Suite 412 Annapolis, MD 21401
+1.410.573.1515

Herbie Kane
hkane@avprojets.com

2001 Dassault Falcon 2000 SN 151 N500MA



SPECIFICATIONS ARE PROVIDED FOR INFORMATIONAL PURPOSES ONLY AND DO NOT CONSTITUTE REPRESENTATIONS OR WARRANTIES. THESE SPECIFICATIONS ARE SUBJECT TO BUYER'S INDEPENDENT VERIFICATION UPON INSPECTION.
THE AIRCRAFT IS SUBJECT TO PRIOR SALE, LEASE AND/OR REMOVAL FROM THE MARKET WITHOUT PRIOR NOTICE. OCTOBER 31, 2024 12:58 PM

AVPROJETS.COM
info@avprojets.com

900 Bestgate Road Suite 412 Annapolis, MD 21401
+1.410.573.1515

Herbie Kane
hkane@avprojets.com

2001 Dassault Falcon 2000 SN 151 N500MA



SPECIFICATIONS ARE PROVIDED FOR INFORMATIONAL PURPOSES ONLY AND DO NOT CONSTITUTE REPRESENTATIONS OR WARRANTIES. THESE SPECIFICATIONS ARE SUBJECT TO BUYER'S INDEPENDENT VERIFICATION UPON INSPECTION.
THE AIRCRAFT IS SUBJECT TO PRIOR SALE, LEASE AND/OR REMOVAL FROM THE MARKET WITHOUT PRIOR NOTICE. OCTOBER 31, 2024 12:58 PM

AVPROJETS.COM
info@avprojets.com

900 Bestgate Road Suite 412 Annapolis, MD 21401
+1.410.573.1515

Herbie Kane
hkane@avprojets.com

2001 Dassault Falcon 2000 SN 151 N500MA



SPECIFICATIONS ARE PROVIDED FOR INFORMATIONAL PURPOSES ONLY AND DO NOT CONSTITUTE REPRESENTATIONS OR WARRANTIES. THESE SPECIFICATIONS ARE SUBJECT TO BUYER'S INDEPENDENT VERIFICATION UPON INSPECTION.
THE AIRCRAFT IS SUBJECT TO PRIOR SALE, LEASE AND/OR REMOVAL FROM THE MARKET WITHOUT PRIOR NOTICE. OCTOBER 31, 2024 12:58 PM

AVPROJETS.COM
info@avprojets.com

900 Bestgate Road Suite 412 Annapolis, MD 21401
+1.410.573.1515

Herbie Kane
hkane@avprojets.com

2001 Dassault Falcon 2000 SN 151 N500MA



SPECIFICATIONS ARE PROVIDED FOR INFORMATIONAL PURPOSES ONLY AND DO NOT CONSTITUTE REPRESENTATIONS OR WARRANTIES. THESE SPECIFICATIONS ARE SUBJECT TO BUYER'S INDEPENDENT VERIFICATION UPON INSPECTION.
THE AIRCRAFT IS SUBJECT TO PRIOR SALE, LEASE AND/OR REMOVAL FROM THE MARKET WITHOUT PRIOR NOTICE. OCTOBER 31, 2024 12:58 PM

AVPROJETS.COM
info@avprojets.com

900 Bestgate Road Suite 412 Annapolis, MD 21401
+1.410.573.1515

Herbie Kane
hkane@avprojets.com

2001 Dassault Falcon 2000 SN 151 N500MA



SPECIFICATIONS ARE PROVIDED FOR INFORMATIONAL PURPOSES ONLY AND DO NOT CONSTITUTE REPRESENTATIONS OR WARRANTIES. THESE SPECIFICATIONS ARE SUBJECT TO BUYER'S INDEPENDENT VERIFICATION UPON INSPECTION.
THE AIRCRAFT IS SUBJECT TO PRIOR SALE, LEASE AND/OR REMOVAL FROM THE MARKET WITHOUT PRIOR NOTICE. OCTOBER 31, 2024 12:58 PM

AVPROJETS.COM
info@avprojets.com

900 Bestgate Road Suite 412 Annapolis, MD 21401
+1.410.573.1515

Herbie Kane
hkane@avprojets.com

2001 Dassault Falcon 2000 SN 151 N500MA



SPECIFICATIONS ARE PROVIDED FOR INFORMATIONAL PURPOSES ONLY AND DO NOT CONSTITUTE REPRESENTATIONS OR WARRANTIES. THESE SPECIFICATIONS ARE SUBJECT TO BUYER'S INDEPENDENT VERIFICATION UPON INSPECTION.
THE AIRCRAFT IS SUBJECT TO PRIOR SALE, LEASE AND/OR REMOVAL FROM THE MARKET WITHOUT PRIOR NOTICE. OCTOBER 31, 2024 12:58 PM

2001 Dassault Falcon 2000 SN 151 N500MA



SPECIFICATIONS ARE PROVIDED FOR INFORMATIONAL PURPOSES ONLY AND DO NOT CONSTITUTE REPRESENTATIONS OR WARRANTIES. THESE SPECIFICATIONS ARE SUBJECT TO BUYER'S INDEPENDENT VERIFICATION UPON INSPECTION.
THE AIRCRAFT IS SUBJECT TO PRIOR SALE, LEASE AND/OR REMOVAL FROM THE MARKET WITHOUT PRIOR NOTICE. OCTOBER 31, 2024 12:58 PM

AVPROJETS.COM
info@avprojets.com

900 Bestgate Road Suite 412 Annapolis, MD 21401
+1.410.573.1515

Herbie Kane
hkane@avprojets.com

2001 Dassault Falcon 2000 SN 151 N500MA



SPECIFICATIONS ARE PROVIDED FOR INFORMATIONAL PURPOSES ONLY AND DO NOT CONSTITUTE REPRESENTATIONS OR WARRANTIES. THESE SPECIFICATIONS ARE SUBJECT TO BUYER'S INDEPENDENT VERIFICATION UPON INSPECTION.
THE AIRCRAFT IS SUBJECT TO PRIOR SALE, LEASE AND/OR REMOVAL FROM THE MARKET WITHOUT PRIOR NOTICE. OCTOBER 31, 2024 12:58 PM

AVPROJETS.COM
info@avprojets.com

900 Bestgate Road Suite 412 Annapolis, MD 21401
+1.410.573.1515

Herbie Kane
hkane@avprojets.com



AVPRO_{INC.}

We perform for our clients, averaging one transaction a week.

We match aircraft to your specifications in a professional and timely manner, allowing you to concentrate on your business, leaving the important details of marketing, market research, negotiating and contracting to us.

When it's time to buy, lease or sell an aircraft, you want to deal with Avpro, a firm known for its Performance for our clients, Integrity in the way we do business, and Reputation as the key ingredient for future business.

SERVING CUSTOMERS
AROUND THE GLOBE

Talk to Us info@avprojets.com +1.410.573.1515

Connect with Us LINKEDIN FACEBOOK TWITTER INSTAGRAM

