

# 2014 PIAGGIO AVANTI II



VT-MSF SN 1234  
TOTAL TIME: 1,130 hours • LANDINGS: 911  
ACS-148

Specifications/Descriptions are provided as information and do not constitute representations or warranties of ACASS Canada Ltd. You should rely on your own inspection of the aircraft. Any proposed transaction is subject to final execution of a contract acceptable in form and substance to ACASS Canada Ltd., its clients, and their counsel.

## HIGHLIGHTS

---

A & B CHECK - IN PROGRESS

POLISHED MAIN WING LEADING EDGES

MTOW INCREASED TO 12,100 LBS

LAST PAINT - 2018

ALWAYS HANGARED

NO DAMAGE HISTORY

## AIRFRAME

---

TOTAL TIME	1,130
LANDINGS	911
ENTRY INTO SERVICE DATE	2014
CERTIFICATION DATE	2014
HOME BASE	India

## ENGINES

---

MAKE/MODEL	P&WC PT6A-66B	
SERIAL NO.	LEFT: PCE-RW0208	RIGHT: PCE-RW0207
TSN	LEFT: 1,130	RIGHT: 1,130
CSN	LEFT: 898	RIGHT: 898

## PROPELLER

---

MAKE/MODEL	LEFT: HC-E5N-3A/HE8218	RIGHT: HC-E5N-3AL/LE8218
SERIAL NO.	LEFT: KU221	RIGHT: HF358
TSN	LEFT: 1,130	RIGHT: 1,130
TBO	Due at 9,000 hours (Blades)	
	Due at 18,000 (Hub)	

Specifications/Descriptions are provided as information and do not constitute representations or warranties of ACASS Canada Ltd. You should rely on your own inspection of the aircraft. Any proposed transaction is subject to final execution of a contract acceptable in form and substance to ACASS Canada Ltd., its clients, and their counsel.

## AVIONICS

---

Collins Pro-Line 21 · UPGRADE IFIS 5000

EFIS (Electronic Flight Instrument System)

GPS (Global Positioning System)

DME (Distance Measuring Equipment)

FGS (Flight Guidance System)

RADALT (Radar Altimeter)

TCAS (Traffic Collision Avoidance System)

Audio Panel

VHF NAV (Very High Frequency Navigation)

VHF COM (Very High Frequency Communication)

EGPWS (Enhanced Ground Proximity Warning System)

WRADAR (Weather Radar)

XPNDR (Transponder)

ELT (Emergency Locator Transmitter)

DCU (Data Concentrator Unit)

FMS (Flight Management System)

CVR (Cockpit Voice Recorder)

FDR (Flight Data Recorder)

MDS (Maintenance Diagnostic System)

EFIS w/ EIS - Three Collins displays AFD-3010,  
two DCP-3030, CCP-3000

Collins GPS-4000A

Single Collins DME-4000 (3 channel) with Antenna

Collins Dual FGC-3003 (A/P,YD and dual Flight  
Director included),three SV0-3000 Servos,  
single FGP-3000 Flight Guidance Panel

Collins AL T-4000 (Operation to 2500 ft) with Antenna

TCAS II - Collins TCAS 4000

Dual Audio Panel - Baker B1045

VHF NAV 1 + ADF - Collins NAV-4000/ VHF NAV 2 -

Collins NAV-4500 VOR/ILS/MKR Receiver w/ Antenna

Dual Collins VHF-4000 w/ 8.33 kHz spacing

Honeywell Mark VIII Extended EGPWS

Collins RTA-852 Colour Radar, 12" Antenna

Dual Mode S Flight ID Diversity Collins TDR-94D

Techtest Model 503 (3 frequency)

Four Collins DCU-3001

Single FMS - Collins FMC-3000

L3 FA2100 CVR/FDR Combo System

L3 FA2100 CVR/FDR Combo System

Collins MDC- 3110

## OTHER NOTABLE FEATURES

---

ADS-B Out

RVSM Compliant

FM immunity

Extended Range Auxiliary Fuel Tank (220 lts - 58 USG)

Electronic charts and maps - Collins ECH 5000 & OVL  
5000

Upgrades for FMS, GPS, PFD & MFD for SBAS and Video  
TCAS II & EGPWS

Upgrade for Integrated Flight Information Collins IFIS 5000

Dual Clock (Flight Hour Meter included)

Dual Master Annunciator, Dual Turn&Slip Indicator (shown  
on the displays)

Reversionary/Miscellaneous Panel

L-3 Communications GH-3100

Standby Cluster Instrument - L3 GH-3100

CDU-3000

DBU-4100

Dual ADS - Collins ADC-3000

Dual AHRS- Collins AHC-3000, FDU-3000

## MAINTENANCE

---

A check

In progress

B check

In progress

Specifications/Descriptions are provided as information and do not constitute representations or warranties of ACASS Canada Ltd. You should rely on your own inspection of the aircraft. Any proposed transaction is subject to final execution of a contract acceptable in form and substance to ACASS Canada Ltd., its clients, and their counsel.

## INTERIOR

---

NUMBER OF PASSENGER SEATS	8
CABIN CONFIGURATION	4 single passenger seats in club arrangement 1 LH forward seat and RH forward 2-place divan with drawers
LAVATORY LOCATION(S)	Aft cabin leftside (8th Seat), fully enclosed lavatory with folding door, sink and water
PARTICULAR FEATURES	Toilet sink with water system Dual foldout executive tables Pyramid cabinet with ice chest and miscellaneous storage Sheepskin covers for cockpit seats

## ENTERTAINMENT & CONNECTIVITY

---

110 VAC power outlets in cockpit and passenger cabin
Dual Cockpit Speaker
Dual hand-held Microphone
Dual Boom/Microphone/Headset

## EXTERIOR

---

EXTERIOR BASE	Wisper Gray with Blue Metal Striping
ADDITIONAL	Polished main wing leading edges Last paint - 2018

Specifications/Descriptions are provided as information and do not constitute representations or warranties of ACASS Canada Ltd. You should rely on your own inspection of the aircraft. Any proposed transaction is subject to final execution of a contract acceptable in form and substance to ACASS Canada Ltd., its clients, and their counsel.

## CABIN LAYOUT

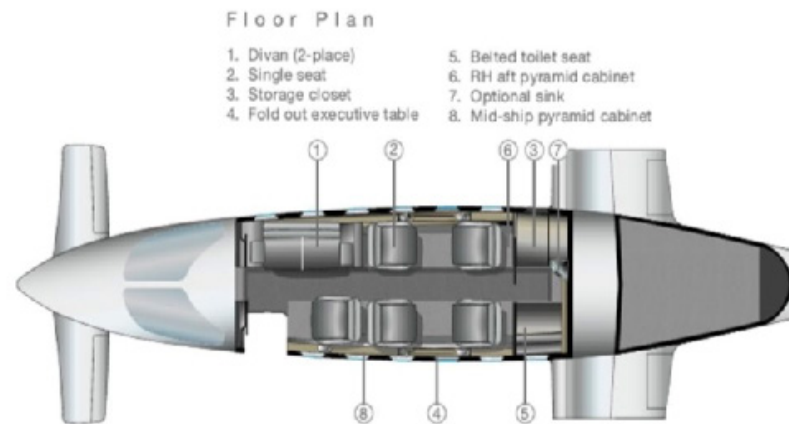

Specifications/Descriptions are provided as information and do not constitute representations or warranties of ACASS Canada Ltd. You should rely on your own inspection of the aircraft. Any proposed transaction is subject to final execution of a contract acceptable in form and substance to ACASS Canada Ltd., its clients, and their counsel.



Specifications/Descriptions are provided as information and do not constitute representations or warranties of ACASS Canada Ltd. You should rely on your own inspection of the aircraft. Any proposed transaction is subject to final execution of a contract acceptable in form and substance to ACASS Canada Ltd., its clients, and their counsel.



Specifications/Descriptions are provided as information and do not constitute representations or warranties of ACASS Canada Ltd. You should rely on your own inspection of the aircraft. Any proposed transaction is subject to final execution of a contract acceptable in form and substance to ACASS Canada Ltd., its clients, and their counsel.



Specifications/Descriptions are provided as information and do not constitute representations or warranties of ACASS Canada Ltd. You should rely on your own inspection of the aircraft. Any proposed transaction is subject to final execution of a contract acceptable in form and substance to ACASS Canada Ltd., its clients, and their counsel.





Specifications/Descriptions are provided as information and do not constitute representations or warranties of ACASS Canada Ltd. You should rely on your own inspection of the aircraft. Any proposed transaction is subject to final execution of a contract acceptable in form and substance to ACASS Canada Ltd., its clients, and their counsel.