

2019 Bombardier ^{SN} 9838
Global 6000



 VIRTUAL TOUR

AVPRO INC.
www.avprojets.com

MANAGING PARTNER
Bob Rabbitt
brabbitt@avprojets.com

EXECUTIVE SALES DIRECTOR
Mike Caruso
mcaruso@avprojets.com

+1.410.573.1515

2019 Global 6000 SN 9838 N50KC

Aircraft Listing Details:

Total Hours: 639
Total Landings: 339

Engines: RR BR710A2-20 Turbopfans w/FADEC

	#1	#2
Total Hours:	639	639
Engine Cycles:	339	339
Serial Numbers:	22807	22808

APU: Honeywell RE-220(GX)

Total Hours: 453
Serial Number: P-987

Aircraft Highlights:

- Outstanding Pedigree – One US Owner Since New
- Like-New Condition with Very Low Hours
- Factory Maintained by Bombardier
- Transferrable Manufacturer Warranties
- HUD / EVS / Synthetic Vision System
- KA Band Satcom / Iridium / Swift Broadband
- Collins Venue CMS / XM Weather
- Flexible Configuration for 14 - 16 Passengers
- 15 & 30 Month Inspections c/w Sept 2021 at BAS-BDL
- Airframe on Bombardier Smart Parts Preferred
- Engines on Rolls Royce Corporate Care
- APU on Honeywell MSP Gold
- FAR Part 135 Commercial Operation

Avionics:

- Rockwell Collins ProLine Fusion Avionics Suite
- Bombardier Vision Flight Deck Avionics Suite
- Head Up Display (HUD)
- Enhanced Vision System (EVS)
- Synthetic Vision System (SVS)
- Dual 3-Axis CAT II Capable Automatic Flight Control System (AFCS) w/AutoThrottle & Autopilot
- Dual Integrated Flight Information System (IFIS) w/Dual File Server Unit
- Four (4) 14"x11" Landscape Active-Matrix Liquid Crystal Displays
- Engine Indication & Crew Alerting System (EICAS)
- Electronic Flight Instrument System (EFIS)
- Integrated Electronic Standby Instrument (ISI)
- Triple VHF Comms
- Dual VHF Navigation Receivers
- Dual Auto Directional Finder (ADF)
- Dual Distance Measuring Equipment (DME)
- Dual Radio Altimeters
- XM Graphical Weather
- MultiScan Weather Radar
- Triple Flight Management System (FMS)
- Dual WAAS GPS
- Single ADS w/Triple Air Data Computers (ADC)
- Triple Inertial Reference System (IRS)
- Terrain Awareness & Warning System (TAWS)
- Traffic Collision Avoidance System (TCAS) w/Change 7.1
- DataLink Capability
- Dual HF's w/SELCAL
- Cockpit Voice Recorder (CVR) – 2 Hours
- Digital Flight Data Recorder (DFDR) – 25 Hours
- Emergency Locator Transmitter (ELT)

SPECIFICATIONS ARE PROVIDED FOR INFORMATIONAL PURPOSES ONLY AND DO NOT CONSTITUTE REPRESENTATIONS OR WARRANTIES. THESE SPECIFICATIONS ARE SUBJECT TO BUYER'S INDEPENDENT VERIFICATION UPON INSPECTION.
THE AIRCRAFT IS SUBJECT TO PRIOR SALE, LEASE AND/OR REMOVAL FROM THE MARKET WITHOUT PRIOR NOTICE. NOVEMBER 22, 2021 12:33 PM

2019 Global 6000 SN 9838 N50KC

Connectivity:

- Honeywell JetWave MCS-8000 KA-Band HS Connectivity
 - Honeywell Aspire 100 Dual Channel Iridium Telephone System
 - Collins SAT-2200 Inmarsat Swift Broadband (SBB) Satellite System
-

Entertainment:

- In-Flight Entertainment (IFC) w/Worldwide Maps & Cabin Briefing
 - Cabin Management System w/Fiber Optic Network
 - One (1) High-Definition Media Streamer w/Two (2) USB Ports
 - Forward & Aft Bulkhead Mounted 24" HD Monitors
 - Dual Blu-ray Player (CD/DVD/MP3)
 - One (1) RJ-45 Port
 - Two (2) USB Charging Ports
 - Two (2) HDMI Ports
 - Two (2) Bluetooth Wireless Audio Receivers
 - One (1) Audio Input (Distribution to Speakers & Headphones)
 - Three (3) HDMI Ports
 - Ten (10) Speakers, Four (4) Subwoofers (Audio/Visual System Connection)
 - Three (3) Noise Cancelling Headsets
 - Three (3) iPad Holders w/Articulating Arms & Charging USB Ports (Plug into Side Ledge Receptacles Located Throughout the Cabin)
-

Maintenance Programs:

- Airframe Enrolled on Bombardier Smart Parts Preferred
- Engines Enrolled on Rolls Royce Corporate Care
- APU Enrolled on Honeywell MSP Gold
- CAMP Maintenance Tracking System

Maintenance Status:

Extensive Maintenance & Improvements c/w September 2021 at Bombardier-Hartford

- 15 & 30 Month Inspections
 - Rockwell Collins GPS-4000S upgrade (SB 700-34-6028 & AD 2021-08-07)
 - Corrosion Protection and Drainage Improvement for the Flaps (SB 700-57-6005, -6008, -6009)
 - Oxygen Supply System – Flexible Hose Replacement (SB 700-35-6005)
 - Installation of a Flight Compartment Printer (SB 700-23-6002)
 - New pilot side windshield installed
 - LH & RH nose wheel assemblies overhauled
 - #1, 3, & 4 main wheel assemblies overhauled
 - #2 main wheel tire replaced
 - Fresh Weight & Balance
-

FAR Part 135 Operations:

- Crew Force Measurement System
 - Three (3) Pilot Crew for up to 12 hours (Cabin)
-

Navigation Compliance:

- CAT II Approach Capable
- Dual WAAS GPS
- ADS-B Out
- RVSM Compliant
- MNPS/BRNAV/RNP 5/P-RNAV
- Traffic Collision Avoidance System (TCAS) w/Change 7.1
- EASA Capable
- EU Air OPS Part CAT Ops

SPECIFICATIONS ARE PROVIDED FOR INFORMATIONAL PURPOSES ONLY AND DO NOT CONSTITUTE REPRESENTATIONS OR WARRANTIES. THESE SPECIFICATIONS ARE SUBJECT TO BUYER'S INDEPENDENT VERIFICATION UPON INSPECTION. THE AIRCRAFT IS SUBJECT TO PRIOR SALE, LEASE AND/OR REMOVAL FROM THE MARKET WITHOUT PRIOR NOTICE. NOVEMBER 22, 2021 12:33 PM

Features/Options:

- Surface Management System-Take Off & Landing Awareness Function (TLAF)
- Flight Compartment Printer (New September 2021)
- Flight Observer Seat
- Electric Accordion Type Window Shades
- Single Point Refuel System
- Passenger Service Unit (PSU)
- Useable Water Tank Storage (28.6 US Gallons)
- Two (2) Life Rafts w/406 MHz ELT
- Three (3) Smoke Detectors w/EICAS Annunciation
- Two (2) Tablet Based EFB Holders w/Charging Capability
- Electronic Charts
- Onboard Maintenance System (OMS)
- Two (2) Door Full Flow Type Thrust Reversers
- Quick Access Recorder
- Automatic Switch (Main Pax Door)
- Crew Oxygen w/Quick Donning Masks
- Independent Passenger Oxygen System
- 115V AC Service
- Nickel Cadmium Batteries
- Galley HD Touchscreen
- High Temp Oven
- Microwave
- Manual Coffee Capsule Machine
- Air Chiller (four perforated removable shelves)
- Chilled Drawer
- Twelve (12) Universal GFCI Electrical Outlets (Cabin)
- Five (5) Wireless Passenger Control Units (WPCU)
- Battery "ON" Reminder Light
- Paint Clear Coat Anti-Stain Band on Lower Engine Cowlings to Prevent Oil Stain

Weights:

Max Ramp	99,750 lbs.
Max Take-Off.....	99,500 lbs.
Max Landing.....	78,600 lbs.
Max Zero Fuel	58,000 lbs.
Basic Operating.....	52,230 lbs.
Max Fuel	45,050 lbs.

Interior:

Flexible Interior Configuration from 14-16 Passengers: 14 Cabin Pax with Full Aft RH Bulkhead installed, 15 Pax with Bulkhead Top Panel removed, 16 Pax including Crew Rest seat (Part 91)

- Forward Crew & Aft Passenger Lavatories
- Aft Cabin Bulkheads with Full Length Decorative Panels & Metal Inlays
- Ventilation Air Duct Covers Upholstered in Leather
- Custom Wool Carpeting

Entryway: Forward Galley with Crew Rest Area, Crew Lav and Electric Pocket Door

Forward Cabin: Four (4) place club seats

Mid Cabin: Four (4) place conference group with hi-lo table opposite a three (3) place divan (certified for 2 passengers take-off and landing due to emergency exit), electric pocket door for additional privacy

Aft Cabin: Two (2) single seats opposite a three (3) place divan (certified for 2 passengers take-off and landing with full bulkhead installed), removable RH bulkhead top panel (allows for use of forward divan position during take-off and landing)

2019 Global 6000 SN 9838 N50KC

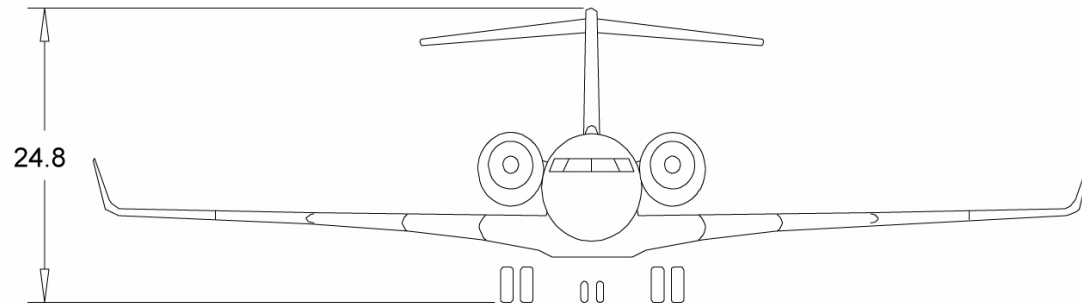
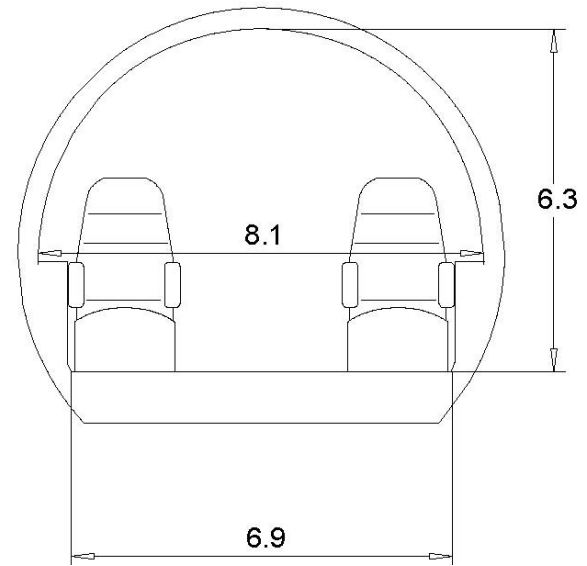
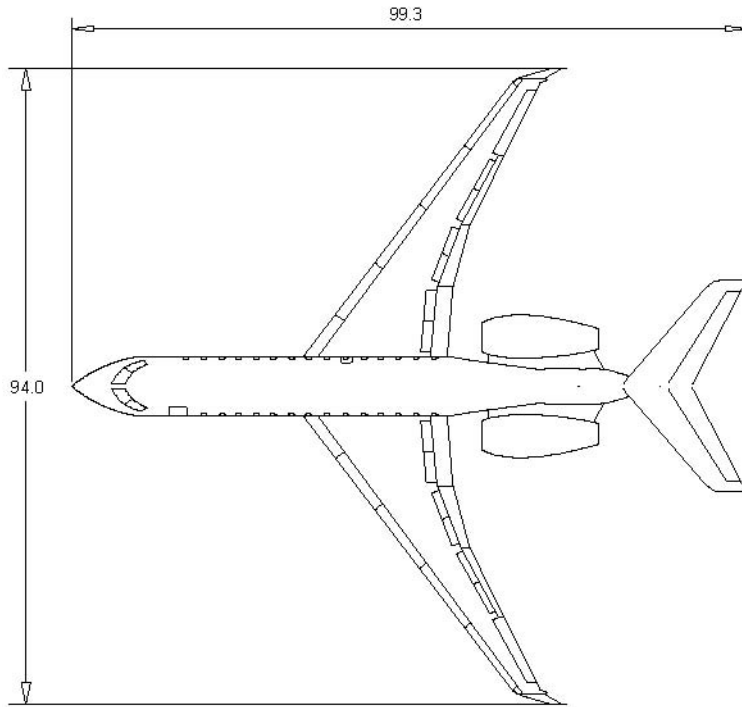

SPECIFICATIONS ARE PROVIDED FOR INFORMATIONAL PURPOSES ONLY AND DO NOT CONSTITUTE REPRESENTATIONS OR WARRANTIES. THESE SPECIFICATIONS ARE SUBJECT TO BUYER'S INDEPENDENT VERIFICATION UPON INSPECTION.
THE AIRCRAFT IS SUBJECT TO PRIOR SALE, LEASE AND/OR REMOVAL FROM THE MARKET WITHOUT PRIOR NOTICE. NOVEMBER 22, 2021 12:33 PM

2019 Global 6000 SN 9838 N50KC



SPECIFICATIONS ARE PROVIDED FOR INFORMATIONAL PURPOSES ONLY AND DO NOT CONSTITUTE REPRESENTATIONS OR WARRANTIES. THESE SPECIFICATIONS ARE SUBJECT TO BUYER'S INDEPENDENT VERIFICATION UPON INSPECTION.
THE AIRCRAFT IS SUBJECT TO PRIOR SALE, LEASE AND/OR REMOVAL FROM THE MARKET WITHOUT PRIOR NOTICE. NOVEMBER 22, 2021 12:33 PM

AVPROJETS.COM

900 Bestgate Road Suite 412 Annapolis, MD 21401
+1.410.573.1515

info@avprojets.com

2019 Global 6000 SN 9838 N50KC



SPECIFICATIONS ARE PROVIDED FOR INFORMATIONAL PURPOSES ONLY AND DO NOT CONSTITUTE REPRESENTATIONS OR WARRANTIES. THESE SPECIFICATIONS ARE SUBJECT TO BUYER'S INDEPENDENT VERIFICATION UPON INSPECTION.
THE AIRCRAFT IS SUBJECT TO PRIOR SALE, LEASE AND/OR REMOVAL FROM THE MARKET WITHOUT PRIOR NOTICE. NOVEMBER 22, 2021 12:33 PM

AVPROJETS.COM

900 Bestgate Road Suite 412 Annapolis, MD 21401
+1.410.573.1515

info@avprojets.com

2019 Global 6000 SN 9838 N50KC



SPECIFICATIONS ARE PROVIDED FOR INFORMATIONAL PURPOSES ONLY AND DO NOT CONSTITUTE REPRESENTATIONS OR WARRANTIES. THESE SPECIFICATIONS ARE SUBJECT TO BUYER'S INDEPENDENT VERIFICATION UPON INSPECTION.
THE AIRCRAFT IS SUBJECT TO PRIOR SALE, LEASE AND/OR REMOVAL FROM THE MARKET WITHOUT PRIOR NOTICE. NOVEMBER 22, 2021 12:33 PM

AVPROJETS.COM

900 Bestgate Road Suite 412 Annapolis, MD 21401
+1.410.573.1515

info@avprojets.com

2019 Global 6000 SN 9838 N50KC



SPECIFICATIONS ARE PROVIDED FOR INFORMATIONAL PURPOSES ONLY AND DO NOT CONSTITUTE REPRESENTATIONS OR WARRANTIES. THESE SPECIFICATIONS ARE SUBJECT TO BUYER'S INDEPENDENT VERIFICATION UPON INSPECTION.
THE AIRCRAFT IS SUBJECT TO PRIOR SALE, LEASE AND/OR REMOVAL FROM THE MARKET WITHOUT PRIOR NOTICE. NOVEMBER 22, 2021 12:33 PM

AVPROJETS.COM

900 Bestgate Road Suite 412 Annapolis, MD 21401
+1.410.573.1515

info@avprojets.com

2019 Global 6000 SN 9838 N50KC



SPECIFICATIONS ARE PROVIDED FOR INFORMATIONAL PURPOSES ONLY AND DO NOT CONSTITUTE REPRESENTATIONS OR WARRANTIES. THESE SPECIFICATIONS ARE SUBJECT TO BUYER'S INDEPENDENT VERIFICATION UPON INSPECTION.
THE AIRCRAFT IS SUBJECT TO PRIOR SALE, LEASE AND/OR REMOVAL FROM THE MARKET WITHOUT PRIOR NOTICE. NOVEMBER 22, 2021 12:33 PM

2019 Global 6000 SN 9838 N50KC



SPECIFICATIONS ARE PROVIDED FOR INFORMATIONAL PURPOSES ONLY AND DO NOT CONSTITUTE REPRESENTATIONS OR WARRANTIES. THESE SPECIFICATIONS ARE SUBJECT TO BUYER'S INDEPENDENT VERIFICATION UPON INSPECTION.
THE AIRCRAFT IS SUBJECT TO PRIOR SALE, LEASE AND/OR REMOVAL FROM THE MARKET WITHOUT PRIOR NOTICE. NOVEMBER 22, 2021 12:33 PM

AVPROJETS.COM

900 Bestgate Road Suite 412 Annapolis, MD 21401
+1.410.573.1515

info@avprojets.com

2019 Global 6000 SN 9838 N50KC



SPECIFICATIONS ARE PROVIDED FOR INFORMATIONAL PURPOSES ONLY AND DO NOT CONSTITUTE REPRESENTATIONS OR WARRANTIES. THESE SPECIFICATIONS ARE SUBJECT TO BUYER'S INDEPENDENT VERIFICATION UPON INSPECTION.
THE AIRCRAFT IS SUBJECT TO PRIOR SALE, LEASE AND/OR REMOVAL FROM THE MARKET WITHOUT PRIOR NOTICE. NOVEMBER 22, 2021 12:33 PM

[AVPROJETS.COM](https://www.avprojets.com)

900 Bestgate Road Suite 412 Annapolis, MD 21401
+1.410.573.1515

info@avprojets.com

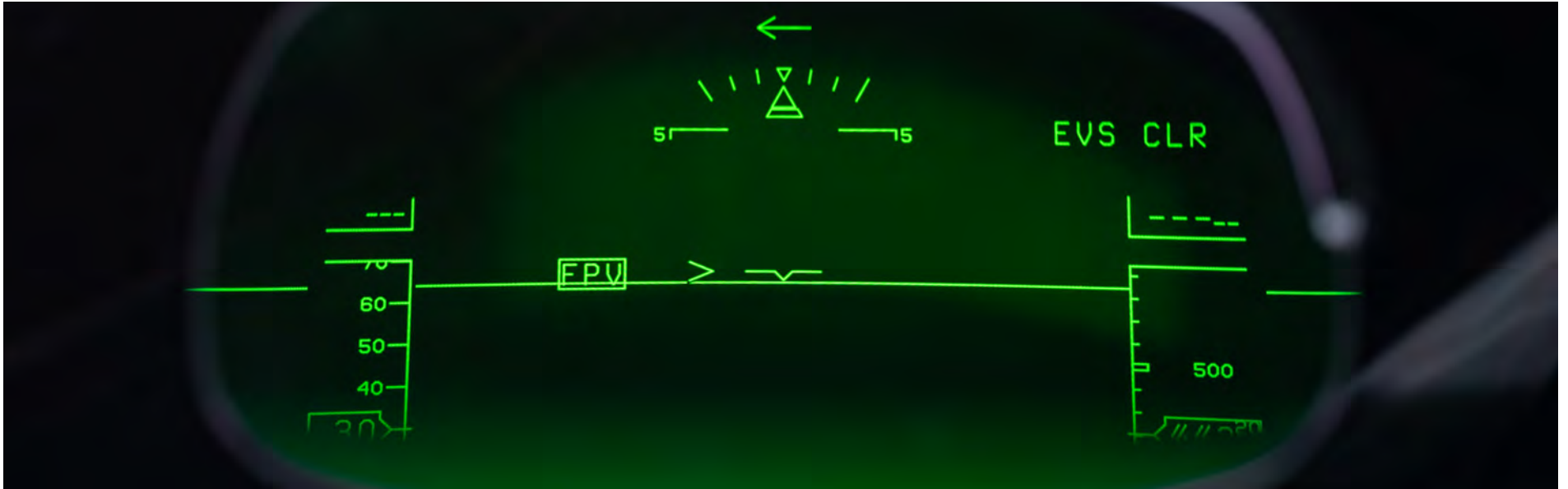

SPECIFICATIONS ARE PROVIDED FOR INFORMATIONAL PURPOSES ONLY AND DO NOT CONSTITUTE REPRESENTATIONS OR WARRANTIES. THESE SPECIFICATIONS ARE SUBJECT TO BUYER'S INDEPENDENT VERIFICATION UPON INSPECTION. THE AIRCRAFT IS SUBJECT TO PRIOR SALE, LEASE AND/OR REMOVAL FROM THE MARKET WITHOUT PRIOR NOTICE. NOVEMBER 22, 2021 12:33 PM



SPECIFICATIONS ARE PROVIDED FOR INFORMATIONAL PURPOSES ONLY AND DO NOT CONSTITUTE REPRESENTATIONS OR WARRANTIES. THESE SPECIFICATIONS ARE SUBJECT TO BUYER'S INDEPENDENT VERIFICATION UPON INSPECTION.
THE AIRCRAFT IS SUBJECT TO PRIOR SALE, LEASE AND/OR REMOVAL FROM THE MARKET WITHOUT PRIOR NOTICE. NOVEMBER 22, 2021 12:33 PM



SPECIFICATIONS ARE PROVIDED FOR INFORMATIONAL PURPOSES ONLY AND DO NOT CONSTITUTE REPRESENTATIONS OR WARRANTIES. THESE SPECIFICATIONS ARE SUBJECT TO BUYER'S INDEPENDENT VERIFICATION UPON INSPECTION. THE AIRCRAFT IS SUBJECT TO PRIOR SALE, LEASE AND/OR REMOVAL FROM THE MARKET WITHOUT PRIOR NOTICE. NOVEMBER 22, 2021 12:33 PM

2019 Global 6000 SN 9838 N50KC



SPECIFICATIONS ARE PROVIDED FOR INFORMATIONAL PURPOSES ONLY AND DO NOT CONSTITUTE REPRESENTATIONS OR WARRANTIES. THESE SPECIFICATIONS ARE SUBJECT TO BUYER'S INDEPENDENT VERIFICATION UPON INSPECTION.
THE AIRCRAFT IS SUBJECT TO PRIOR SALE, LEASE AND/OR REMOVAL FROM THE MARKET WITHOUT PRIOR NOTICE. NOVEMBER 22, 2021 12:33 PM

AVPROJETS.COM

900 Bestgate Road Suite 412 Annapolis, MD 21401
+1.410.573.1515

info@avprojets.com

2019 Global 6000 SN 9838 N50KC



SPECIFICATIONS ARE PROVIDED FOR INFORMATIONAL PURPOSES ONLY AND DO NOT CONSTITUTE REPRESENTATIONS OR WARRANTIES. THESE SPECIFICATIONS ARE SUBJECT TO BUYER'S INDEPENDENT VERIFICATION UPON INSPECTION.
THE AIRCRAFT IS SUBJECT TO PRIOR SALE, LEASE AND/OR REMOVAL FROM THE MARKET WITHOUT PRIOR NOTICE. NOVEMBER 22, 2021 12:33 PM

[AVPROJETS.COM](https://www.avprojets.com)

900 Bestgate Road Suite 412 Annapolis, MD 21401
+1.410.573.1515

info@avprojets.com



SPECIFICATIONS ARE PROVIDED FOR INFORMATIONAL PURPOSES ONLY AND DO NOT CONSTITUTE REPRESENTATIONS OR WARRANTIES. THESE SPECIFICATIONS ARE SUBJECT TO BUYER'S INDEPENDENT VERIFICATION UPON INSPECTION.
THE AIRCRAFT IS SUBJECT TO PRIOR SALE, LEASE AND/OR REMOVAL FROM THE MARKET WITHOUT PRIOR NOTICE. NOVEMBER 22, 2021 12:33 PM

2019 Global 6000 SN 9838 N50KC



SPECIFICATIONS ARE PROVIDED FOR INFORMATIONAL PURPOSES ONLY AND DO NOT CONSTITUTE REPRESENTATIONS OR WARRANTIES. THESE SPECIFICATIONS ARE SUBJECT TO BUYER'S INDEPENDENT VERIFICATION UPON INSPECTION.
THE AIRCRAFT IS SUBJECT TO PRIOR SALE, LEASE AND/OR REMOVAL FROM THE MARKET WITHOUT PRIOR NOTICE. NOVEMBER 22, 2021 12:33 PM

AVPROJETS.COM

900 Bestgate Road Suite 412 Annapolis, MD 21401
+1.410.573.1515

info@avprojets.com

2019 Global 6000 SN 9838 N50KC



SPECIFICATIONS ARE PROVIDED FOR INFORMATIONAL PURPOSES ONLY AND DO NOT CONSTITUTE REPRESENTATIONS OR WARRANTIES. THESE SPECIFICATIONS ARE SUBJECT TO BUYER'S INDEPENDENT VERIFICATION UPON INSPECTION.
THE AIRCRAFT IS SUBJECT TO PRIOR SALE, LEASE AND/OR REMOVAL FROM THE MARKET WITHOUT PRIOR NOTICE. NOVEMBER 22, 2021 12:33 PM

AVPROJETS.COM

900 Bestgate Road Suite 412 Annapolis, MD 21401
+1.410.573.1515

info@avprojets.com

2019 Global 6000 SN 9838 N50KC



SPECIFICATIONS ARE PROVIDED FOR INFORMATIONAL PURPOSES ONLY AND DO NOT CONSTITUTE REPRESENTATIONS OR WARRANTIES. THESE SPECIFICATIONS ARE SUBJECT TO BUYER'S INDEPENDENT VERIFICATION UPON INSPECTION.
THE AIRCRAFT IS SUBJECT TO PRIOR SALE, LEASE AND/OR REMOVAL FROM THE MARKET WITHOUT PRIOR NOTICE. NOVEMBER 22, 2021 12:33 PM

[AVPROJETS.COM](https://www.avprojets.com)

900 Bestgate Road Suite 412 Annapolis, MD 21401
+1.410.573.1515

info@avprojets.com



SPECIFICATIONS ARE PROVIDED FOR INFORMATIONAL PURPOSES ONLY AND DO NOT CONSTITUTE REPRESENTATIONS OR WARRANTIES. THESE SPECIFICATIONS ARE SUBJECT TO BUYER'S INDEPENDENT VERIFICATION UPON INSPECTION.
THE AIRCRAFT IS SUBJECT TO PRIOR SALE, LEASE AND/OR REMOVAL FROM THE MARKET WITHOUT PRIOR NOTICE. NOVEMBER 22, 2021 12:33 PM



SPECIFICATIONS ARE PROVIDED FOR INFORMATIONAL PURPOSES ONLY AND DO NOT CONSTITUTE REPRESENTATIONS OR WARRANTIES. THESE SPECIFICATIONS ARE SUBJECT TO BUYER'S INDEPENDENT VERIFICATION UPON INSPECTION.
THE AIRCRAFT IS SUBJECT TO PRIOR SALE, LEASE AND/OR REMOVAL FROM THE MARKET WITHOUT PRIOR NOTICE. NOVEMBER 22, 2021 12:33 PM



AVPRO INC.

▪ CELEBRATING **30** YEARS OF EXCELLENCE ▪

We perform for our clients, averaging two transactions a week.

We match aircraft to your specifications in a professional and timely manner, allowing you to concentrate on your business, leaving the important details of marketing, market research, negotiating and contracting to us.

Avpro offers aircraft financing advisory services. We have the expertise to navigate the appropriate structure, costs and terms to help you meet your objectives. We are ready to provide advice, analysis and sourcing of the lender best suited to meet your requirements.

SERVING CUSTOMERS
AROUND THE GLOBE

Talk to Us info@avprojets.com +1.410.573.1515

Connect with Us LINKEDIN FACEBOOK TWITTER INSTAGRAM

