

2019 Pilatus ^{SN} 0152

PC-24



CLICK TO VIEW
VIRTUAL TOUR



AVPRO INC.
www.avprojets.com

EXECUTIVE SALES DIRECTOR

Eddie Kilkeary III
ekilkeary@avprojets.com
+1.410.573.1515

2019 Pilatus PC-24 SN 0152 N1040C (to be retained)

Aircraft Listing Details:

Total Hours: 326

Total Landings: 483

Engines: Williams FJ44-4AZPM

	#1	#2
Total Hours:	326	326
Engine Cycles:	483	483
Serial Numbers:	295113	295114

Aircraft Highlights:

- One Exceptional Corporate Owner & Operator Since New
- Remaining Pilatus Factory Warranty
- Engines Enrolled on TAP Blue
- Enrolled on MSP Avionics Protection Plan
- Interchangeable 6 Passenger / 8 Passenger Floorplans
- GoGo L3 Avance
- Professional World Avionics Package
- Like New Cosmetic Condition

Avionics:

- Honeywell Primus Epic 2.0
- Pilatus Advanced Cockpit Environment (ACE™)
- Dual Flat Panel Primary Flight Displays
- SmartView™ Synthetic Vision
- Dual Audio/Marker Panels
- Three-Axis Autopilot w/Dual Yaw Damper
- Flight Guidance Panel
- Dual Multifunction Displays
- Functionality Dual Multi-Mode Digital Radios
- Dual Attitude Reference Systems Including IRS & AHRS
- Dual ATC Transponders
- DME
- Radar Altimeter
- EGPWS- Class A
- TCAS II
- Auto Throttle System
- Utility Management System
- Dual Pitot-Static Systems
- Dual AOA Sensors
- RDR 2100 Weather Radar
- Integrated Maintenance Computer
- Stormscope (WX 500) Honeywell Dual Chartlink CVR and FDR
- ESIS Cockpit Voice and Flight Data Recorder

SPECIFICATIONS ARE PROVIDED FOR INFORMATIONAL PURPOSES ONLY AND DO NOT CONSTITUTE REPRESENTATIONS OR WARRANTIES. THESE SPECIFICATIONS ARE SUBJECT TO BUYER'S INDEPENDENT VERIFICATION UPON INSPECTION.
THE AIRCRAFT IS SUBJECT TO PRIOR SALE, LEASE AND/OR REMOVAL FROM THE MARKET WITHOUT PRIOR NOTICE. MARCH 9, 2023 3:27 PM

2019 Pilatus PC-24 SN 0152 N1040C (to be retained)

Professional World Package Including:

- ADS-B In & Out
- Wireless Connected Flight Deck
- ICMS Cabin Entertainment System w/XML, Music, Movies & Flight Tracking
- Cabin Controlled Lighting & Temperature Control Thru i-Pad
- Graphical XM Weather + WX500 Stormscope
- Honeywell Dual Chart Link Displays
- 2D Airport Maps
- Eight (8) USB Power Ports; Four (4) 110 AC Jacks
- Cockpit Safety Services Satellite Phone

Maintenance Programs:

- Engines Enrolled on TAP Blue
- Enrolled on MSP Avionics Protection Plan
- CAMP Maintenance Tracking

Inspection Status:

<u>Inspection</u>	<u>Compliance</u>	<u>Next Due</u>
12 Month	November 2022	October 2023
1200 Hours/24 Month	November 2021	October 2023
2400 Hours/48 Month	October 2019	October 2023
24 Month	November 2021	October 2023
48 Month	October 2019	October 2023

Navigation Compliance:

- CPDLC Capability
- ADS-B In & Out
- Steep Approach
- RVSM Compliant

SPECIFICATIONS ARE PROVIDED FOR INFORMATIONAL PURPOSES ONLY AND DO NOT CONSTITUTE REPRESENTATIONS OR WARRANTIES. THESE SPECIFICATIONS ARE SUBJECT TO BUYER'S INDEPENDENT VERIFICATION UPON INSPECTION.
THE AIRCRAFT IS SUBJECT TO PRIOR SALE, LEASE AND/OR REMOVAL FROM THE MARKET WITHOUT PRIOR NOTICE. MARCH 9, 2023 3:27 PM

2019 Pilatus PC-24 SN 0152 N1040C (to be retained)

Features/Options:

- Dual Chartlink
- Commercial Operations Kit
- Steep Approach
- Premium Interior Lighting Package
- LED Exterior Lights
- Pulsing Recognition Lights
- Soft-Field Tires for Unimproved Field Landings
- Electrically Powered Vapor Cycle
- Air Conditioning
- Dual Zone Temperature Control
- Supplemental Oxygen System
- 77 cu ft Oxygen Cylinder
- Wireless Connected Flight Deck
- NiCad Batteries
- Complete Internal and External Corrosion Protection
- Anti-icing Protection
- Cabin Pressurization Control System
- Passenger Announcement System
- Power Outlets in Cockpit and Cabin
- Outward Opening
- Airstair Door with Chromed Handrail
- Cabin Entry Stone Floor
- L3 Micro QAR - FOQA
- PPG Pilot/Copilot Windscreens
- Pilot/Copilot EVAS

Interior:

Interchangeable 6 Passenger / 8 Passenger Floorplan.

Exterior:

Overall Matterhorn White w/Crest Blue & Lt. Gray Striping.



SPECIFICATIONS ARE PROVIDED FOR INFORMATIONAL PURPOSES ONLY AND DO NOT CONSTITUTE REPRESENTATIONS OR WARRANTIES. THESE SPECIFICATIONS ARE SUBJECT TO BUYER'S INDEPENDENT VERIFICATION UPON INSPECTION.
THE AIRCRAFT IS SUBJECT TO PRIOR SALE, LEASE AND/OR REMOVAL FROM THE MARKET WITHOUT PRIOR NOTICE. MARCH 9, 2023 3:27 PM

2019 Pilatus PC-24 SN 0152 N1040C (to be retained)

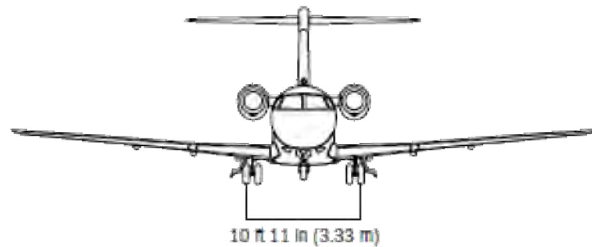
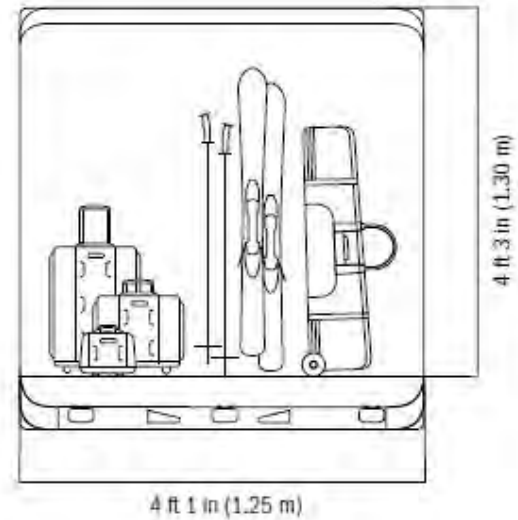
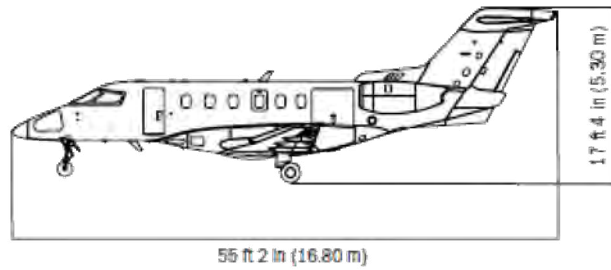
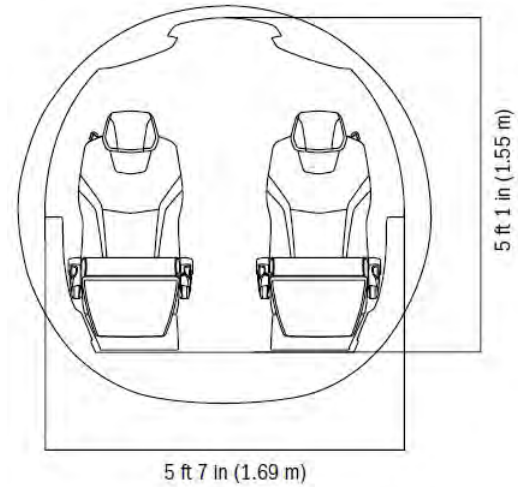
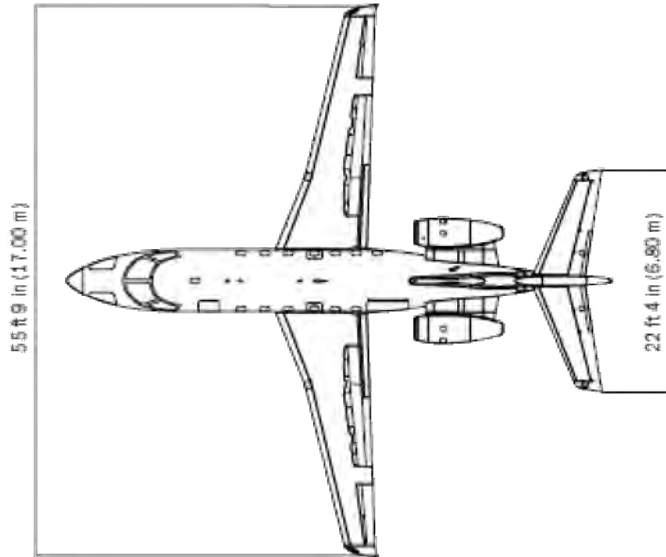

SPECIFICATIONS ARE PROVIDED FOR INFORMATIONAL PURPOSES ONLY AND DO NOT CONSTITUTE REPRESENTATIONS OR WARRANTIES. THESE SPECIFICATIONS ARE SUBJECT TO BUYER'S INDEPENDENT VERIFICATION UPON INSPECTION.
THE AIRCRAFT IS SUBJECT TO PRIOR SALE, LEASE AND/OR REMOVAL FROM THE MARKET WITHOUT PRIOR NOTICE. MARCH 9, 2023 3:27 PM

2019 Pilatus PC-24 SN 0152 N1040C (to be retained)



SPECIFICATIONS ARE PROVIDED FOR INFORMATIONAL PURPOSES ONLY AND DO NOT CONSTITUTE REPRESENTATIONS OR WARRANTIES. THESE SPECIFICATIONS ARE SUBJECT TO BUYER'S INDEPENDENT VERIFICATION UPON INSPECTION.
THE AIRCRAFT IS SUBJECT TO PRIOR SALE, LEASE AND/OR REMOVAL FROM THE MARKET WITHOUT PRIOR NOTICE. MARCH 9, 2023 3:27 PM

AVPROJETS.COM
info@avprojets.com

900 Bestgate Road Suite 412 Annapolis, MD 21401
+1.410.573.1515

Eddie Kilkeary III
ekilkeary@avprojets.com

2019 Pilatus PC-24 SN 0152 N1040C (to be retained)



SPECIFICATIONS ARE PROVIDED FOR INFORMATIONAL PURPOSES ONLY AND DO NOT CONSTITUTE REPRESENTATIONS OR WARRANTIES. THESE SPECIFICATIONS ARE SUBJECT TO BUYER'S INDEPENDENT VERIFICATION UPON INSPECTION.
THE AIRCRAFT IS SUBJECT TO PRIOR SALE, LEASE AND/OR REMOVAL FROM THE MARKET WITHOUT PRIOR NOTICE. MARCH 9, 2023 3:27 PM

AVPROJETS.COM
info@avprojets.com

900 Bestgate Road Suite 412 Annapolis, MD 21401
+1.410.573.1515

Eddie Kilkeary III
ekilkeary@avprojets.com

2019 Pilatus PC-24 SN 0152 N1040C (to be retained)



SPECIFICATIONS ARE PROVIDED FOR INFORMATIONAL PURPOSES ONLY AND DO NOT CONSTITUTE REPRESENTATIONS OR WARRANTIES. THESE SPECIFICATIONS ARE SUBJECT TO BUYER'S INDEPENDENT VERIFICATION UPON INSPECTION.
THE AIRCRAFT IS SUBJECT TO PRIOR SALE, LEASE AND/OR REMOVAL FROM THE MARKET WITHOUT PRIOR NOTICE. MARCH 9, 2023 3:27 PM

AVPROJETS.COM
info@avprojets.com

900 Bestgate Road Suite 412 Annapolis, MD 21401
+1.410.573.1515

Eddie Kilkeary III
ekilkeary@avprojets.com

2019 Pilatus PC-24 SN 0152 N1040C (to be retained)



SPECIFICATIONS ARE PROVIDED FOR INFORMATIONAL PURPOSES ONLY AND DO NOT CONSTITUTE REPRESENTATIONS OR WARRANTIES. THESE SPECIFICATIONS ARE SUBJECT TO BUYER'S INDEPENDENT VERIFICATION UPON INSPECTION.
THE AIRCRAFT IS SUBJECT TO PRIOR SALE, LEASE AND/OR REMOVAL FROM THE MARKET WITHOUT PRIOR NOTICE. MARCH 9, 2023 3:27 PM

AVPROJETS.COM
info@avprojets.com

900 Bestgate Road Suite 412 Annapolis, MD 21401
+1.410.573.1515

Eddie Kilkeary III
ekilkeary@avprojets.com

2019 Pilatus PC-24 SN 0152 N1040C (to be retained)



SPECIFICATIONS ARE PROVIDED FOR INFORMATIONAL PURPOSES ONLY AND DO NOT CONSTITUTE REPRESENTATIONS OR WARRANTIES. THESE SPECIFICATIONS ARE SUBJECT TO BUYER'S INDEPENDENT VERIFICATION UPON INSPECTION.
THE AIRCRAFT IS SUBJECT TO PRIOR SALE, LEASE AND/OR REMOVAL FROM THE MARKET WITHOUT PRIOR NOTICE. MARCH 9, 2023 3:27 PM

AVPROJETS.COM
info@avprojets.com

900 Bestgate Road Suite 412 Annapolis, MD 21401
+1.410.573.1515

Eddie Kilkeary III
ekilkeary@avprojets.com

2019 Pilatus PC-24 SN 0152 N1040C (to be retained)



SPECIFICATIONS ARE PROVIDED FOR INFORMATIONAL PURPOSES ONLY AND DO NOT CONSTITUTE REPRESENTATIONS OR WARRANTIES. THESE SPECIFICATIONS ARE SUBJECT TO BUYER'S INDEPENDENT VERIFICATION UPON INSPECTION.
THE AIRCRAFT IS SUBJECT TO PRIOR SALE, LEASE AND/OR REMOVAL FROM THE MARKET WITHOUT PRIOR NOTICE. MARCH 9, 2023 3:27 PM

AVPROJETS.COM
info@avprojets.com

900 Bestgate Road Suite 412 Annapolis, MD 21401
+1.410.573.1515

Eddie Kilkeary III
ekilkeary@avprojets.com

2019 Pilatus PC-24 SN 0152 N1040C (to be retained)



SPECIFICATIONS ARE PROVIDED FOR INFORMATIONAL PURPOSES ONLY AND DO NOT CONSTITUTE REPRESENTATIONS OR WARRANTIES. THESE SPECIFICATIONS ARE SUBJECT TO BUYER'S INDEPENDENT VERIFICATION UPON INSPECTION.
THE AIRCRAFT IS SUBJECT TO PRIOR SALE, LEASE AND/OR REMOVAL FROM THE MARKET WITHOUT PRIOR NOTICE. MARCH 9, 2023 3:27 PM

AVPROJETS.COM
info@avprojets.com

900 Bestgate Road Suite 412 Annapolis, MD 21401
+1.410.573.1515

Eddie Kilkeary III
ekilkeary@avprojets.com

2019 Pilatus PC-24 SN 0152 N1040C (to be retained)



SPECIFICATIONS ARE PROVIDED FOR INFORMATIONAL PURPOSES ONLY AND DO NOT CONSTITUTE REPRESENTATIONS OR WARRANTIES. THESE SPECIFICATIONS ARE SUBJECT TO BUYER'S INDEPENDENT VERIFICATION UPON INSPECTION.
THE AIRCRAFT IS SUBJECT TO PRIOR SALE, LEASE AND/OR REMOVAL FROM THE MARKET WITHOUT PRIOR NOTICE. MARCH 9, 2023 3:27 PM

AVPROJETS.COM
info@avprojets.com

900 Bestgate Road Suite 412 Annapolis, MD 21401
+1.410.573.1515

Eddie Kilkeary III
ekilkeary@avprojets.com

2019 Pilatus PC-24 SN 0152 N1040C (to be retained)



SPECIFICATIONS ARE PROVIDED FOR INFORMATIONAL PURPOSES ONLY AND DO NOT CONSTITUTE REPRESENTATIONS OR WARRANTIES. THESE SPECIFICATIONS ARE SUBJECT TO BUYER'S INDEPENDENT VERIFICATION UPON INSPECTION.
THE AIRCRAFT IS SUBJECT TO PRIOR SALE, LEASE AND/OR REMOVAL FROM THE MARKET WITHOUT PRIOR NOTICE. MARCH 9, 2023 3:27 PM

AVPROJETS.COM
info@avprojets.com

900 Bestgate Road Suite 412 Annapolis, MD 21401
+1.410.573.1515

Eddie Kilkeary III
ekilkeary@avprojets.com

2019 Pilatus PC-24 SN 0152 N1040C (to be retained)



SPECIFICATIONS ARE PROVIDED FOR INFORMATIONAL PURPOSES ONLY AND DO NOT CONSTITUTE REPRESENTATIONS OR WARRANTIES. THESE SPECIFICATIONS ARE SUBJECT TO BUYER'S INDEPENDENT VERIFICATION UPON INSPECTION.
THE AIRCRAFT IS SUBJECT TO PRIOR SALE, LEASE AND/OR REMOVAL FROM THE MARKET WITHOUT PRIOR NOTICE. MARCH 9, 2023 3:27 PM

AVPROJETS.COM
info@avprojets.com

900 Bestgate Road Suite 412 Annapolis, MD 21401
+1.410.573.1515

Eddie Kilkeary III
ekilkeary@avprojets.com

2019 Pilatus PC-24 SN 0152 N1040C (to be retained)



SPECIFICATIONS ARE PROVIDED FOR INFORMATIONAL PURPOSES ONLY AND DO NOT CONSTITUTE REPRESENTATIONS OR WARRANTIES. THESE SPECIFICATIONS ARE SUBJECT TO BUYER'S INDEPENDENT VERIFICATION UPON INSPECTION.
THE AIRCRAFT IS SUBJECT TO PRIOR SALE, LEASE AND/OR REMOVAL FROM THE MARKET WITHOUT PRIOR NOTICE. MARCH 9, 2023 3:27 PM

AVPROJETS.COM
info@avprojets.com

900 Bestgate Road Suite 412 Annapolis, MD 21401
+1.410.573.1515

Eddie Kilkeary III
ekilkeary@avprojets.com

2019 Pilatus PC-24 SN 0152 N1040C (to be retained)



SPECIFICATIONS ARE PROVIDED FOR INFORMATIONAL PURPOSES ONLY AND DO NOT CONSTITUTE REPRESENTATIONS OR WARRANTIES. THESE SPECIFICATIONS ARE SUBJECT TO BUYER'S INDEPENDENT VERIFICATION UPON INSPECTION. THE AIRCRAFT IS SUBJECT TO PRIOR SALE, LEASE AND/OR REMOVAL FROM THE MARKET WITHOUT PRIOR NOTICE. MARCH 9, 2023 3:27 PM

AVPROJETS.COM
info@avprojets.com

900 Bestgate Road Suite 412 Annapolis, MD 21401
+1.410.573.1515

Eddie Kilkeary III
ekilkeary@avprojets.com

2019 Pilatus PC-24 SN 0152 N1040C (to be retained)



SPECIFICATIONS ARE PROVIDED FOR INFORMATIONAL PURPOSES ONLY AND DO NOT CONSTITUTE REPRESENTATIONS OR WARRANTIES. THESE SPECIFICATIONS ARE SUBJECT TO BUYER'S INDEPENDENT VERIFICATION UPON INSPECTION.
THE AIRCRAFT IS SUBJECT TO PRIOR SALE, LEASE AND/OR REMOVAL FROM THE MARKET WITHOUT PRIOR NOTICE. MARCH 9, 2023 3:27 PM

AVPROJETS.COM
info@avprojets.com

900 Bestgate Road Suite 412 Annapolis, MD 21401
+1.410.573.1515

Eddie Kilkeary III
ekilkeary@avprojets.com

2019 Pilatus PC-24 SN 0152 N1040C (to be retained)



SPECIFICATIONS ARE PROVIDED FOR INFORMATIONAL PURPOSES ONLY AND DO NOT CONSTITUTE REPRESENTATIONS OR WARRANTIES. THESE SPECIFICATIONS ARE SUBJECT TO BUYER'S INDEPENDENT VERIFICATION UPON INSPECTION.
THE AIRCRAFT IS SUBJECT TO PRIOR SALE, LEASE AND/OR REMOVAL FROM THE MARKET WITHOUT PRIOR NOTICE. MARCH 9, 2023 3:27 PM

AVPROJETS.COM
info@avprojets.com

900 Bestgate Road Suite 412 Annapolis, MD 21401
+1.410.573.1515

Eddie Kilkeary III
ekilkeary@avprojets.com

2019 Pilatus PC-24 SN 0152 N1040C (to be retained)



SPECIFICATIONS ARE PROVIDED FOR INFORMATIONAL PURPOSES ONLY AND DO NOT CONSTITUTE REPRESENTATIONS OR WARRANTIES. THESE SPECIFICATIONS ARE SUBJECT TO BUYER'S INDEPENDENT VERIFICATION UPON INSPECTION.
THE AIRCRAFT IS SUBJECT TO PRIOR SALE, LEASE AND/OR REMOVAL FROM THE MARKET WITHOUT PRIOR NOTICE. MARCH 9, 2023 3:27 PM

AVPROJETS.COM
info@avprojets.com

900 Bestgate Road Suite 412 Annapolis, MD 21401
+1.410.573.1515

Eddie Kilkeary III
ekilkeary@avprojets.com

2019 Pilatus PC-24 SN 0152 N1040C (to be retained)



SPECIFICATIONS ARE PROVIDED FOR INFORMATIONAL PURPOSES ONLY AND DO NOT CONSTITUTE REPRESENTATIONS OR WARRANTIES. THESE SPECIFICATIONS ARE SUBJECT TO BUYER'S INDEPENDENT VERIFICATION UPON INSPECTION.
THE AIRCRAFT IS SUBJECT TO PRIOR SALE, LEASE AND/OR REMOVAL FROM THE MARKET WITHOUT PRIOR NOTICE. MARCH 9, 2023 3:27 PM

AVPROJETS.COM
info@avprojets.com

900 Bestgate Road Suite 412 Annapolis, MD 21401
+1.410.573.1515

Eddie Kilkeary III
ekilkeary@avprojets.com

2019 Pilatus PC-24 SN 0152 N1040C (to be retained)



SPECIFICATIONS ARE PROVIDED FOR INFORMATIONAL PURPOSES ONLY AND DO NOT CONSTITUTE REPRESENTATIONS OR WARRANTIES. THESE SPECIFICATIONS ARE SUBJECT TO BUYER'S INDEPENDENT VERIFICATION UPON INSPECTION.
THE AIRCRAFT IS SUBJECT TO PRIOR SALE, LEASE AND/OR REMOVAL FROM THE MARKET WITHOUT PRIOR NOTICE. MARCH 9, 2023 3:27 PM

AVPROJETS.COM
info@avprojets.com

900 Bestgate Road Suite 412 Annapolis, MD 21401
+1.410.573.1515

Eddie Kilkeary III
ekilkeary@avprojets.com

2019 Pilatus PC-24 SN 0152 N1040C *(to be retained)*



SPECIFICATIONS ARE PROVIDED FOR INFORMATIONAL PURPOSES ONLY AND DO NOT CONSTITUTE REPRESENTATIONS OR WARRANTIES. THESE SPECIFICATIONS ARE SUBJECT TO BUYER'S INDEPENDENT VERIFICATION UPON INSPECTION.
THE AIRCRAFT IS SUBJECT TO PRIOR SALE, LEASE AND/OR REMOVAL FROM THE MARKET WITHOUT PRIOR NOTICE. MARCH 9, 2023 3:27 PM

AVPROJETS.COM
info@avprojets.com

900 Bestgate Road Suite 412 Annapolis, MD 21401
+1.410.573.1515

Eddie Kilkeary III
ekilkeary@avprojets.com

2019 Pilatus PC-24 SN 0152 N1040C (to be retained)



SPECIFICATIONS ARE PROVIDED FOR INFORMATIONAL PURPOSES ONLY AND DO NOT CONSTITUTE REPRESENTATIONS OR WARRANTIES. THESE SPECIFICATIONS ARE SUBJECT TO BUYER'S INDEPENDENT VERIFICATION UPON INSPECTION.
THE AIRCRAFT IS SUBJECT TO PRIOR SALE, LEASE AND/OR REMOVAL FROM THE MARKET WITHOUT PRIOR NOTICE. MARCH 9, 2023 3:27 PM

AVPROJETS.COM
info@avprojets.com

900 Bestgate Road Suite 412 Annapolis, MD 21401
+1.410.573.1515

Eddie Kilkeary III
ekilkeary@avprojets.com

2019 Pilatus PC-24 SN 0152 N1040C (to be retained)



SPECIFICATIONS ARE PROVIDED FOR INFORMATIONAL PURPOSES ONLY AND DO NOT CONSTITUTE REPRESENTATIONS OR WARRANTIES. THESE SPECIFICATIONS ARE SUBJECT TO BUYER'S INDEPENDENT VERIFICATION UPON INSPECTION.
THE AIRCRAFT IS SUBJECT TO PRIOR SALE, LEASE AND/OR REMOVAL FROM THE MARKET WITHOUT PRIOR NOTICE. MARCH 9, 2023 3:27 PM

AVPROJETS.COM
info@avprojets.com

900 Bestgate Road Suite 412 Annapolis, MD 21401
+1.410.573.1515

Eddie Kilkeary III
ekilkeary@avprojets.com

2019 Pilatus PC-24 SN 0152 N1040C (to be retained)



SPECIFICATIONS ARE PROVIDED FOR INFORMATIONAL PURPOSES ONLY AND DO NOT CONSTITUTE REPRESENTATIONS OR WARRANTIES. THESE SPECIFICATIONS ARE SUBJECT TO BUYER'S INDEPENDENT VERIFICATION UPON INSPECTION. THE AIRCRAFT IS SUBJECT TO PRIOR SALE, LEASE AND/OR REMOVAL FROM THE MARKET WITHOUT PRIOR NOTICE. MARCH 9, 2023 3:27 PM

AVPROJETS.COM
info@avprojets.com

900 Bestgate Road Suite 412 Annapolis, MD 21401
+1.410.573.1515

Eddie Kilkeary III
ekilkeary@avprojets.com

2019 Pilatus PC-24 SN 0152 N1040C (to be retained)



SPECIFICATIONS ARE PROVIDED FOR INFORMATIONAL PURPOSES ONLY AND DO NOT CONSTITUTE REPRESENTATIONS OR WARRANTIES. THESE SPECIFICATIONS ARE SUBJECT TO BUYER'S INDEPENDENT VERIFICATION UPON INSPECTION.
THE AIRCRAFT IS SUBJECT TO PRIOR SALE, LEASE AND/OR REMOVAL FROM THE MARKET WITHOUT PRIOR NOTICE. MARCH 9, 2023 3:27 PM

AVPROJETS.COM
info@avprojets.com

900 Bestgate Road Suite 412 Annapolis, MD 21401
+1.410.573.1515

Eddie Kilkeary III
ekilkeary@avprojets.com



AVPRO INC.

CELEBRATING OVER **30** YEARS OF EXCELLENCE

We perform for our clients, averaging two transactions a week.

We match aircraft to your specifications in a professional and timely manner, allowing you to concentrate on your business, leaving the important details of marketing, market research, negotiating and contracting to us.

Avpro offers aircraft financing advisory services. We have the expertise to navigate the appropriate structure, costs and terms to help you meet your objectives. We are ready to provide advice, analysis and sourcing of the lender best suited to meet your requirements.

SERVING CUSTOMERS
AROUND THE GLOBE

Talk to Us info@avprojets.com +1.410.573.1515

Connect with Us LINKEDIN FACEBOOK TWITTER INSTAGRAM

